

Installation and Maintenance manual

TIE BAR

A95

ENGLISH

ITALIANO

FRANÇAIS

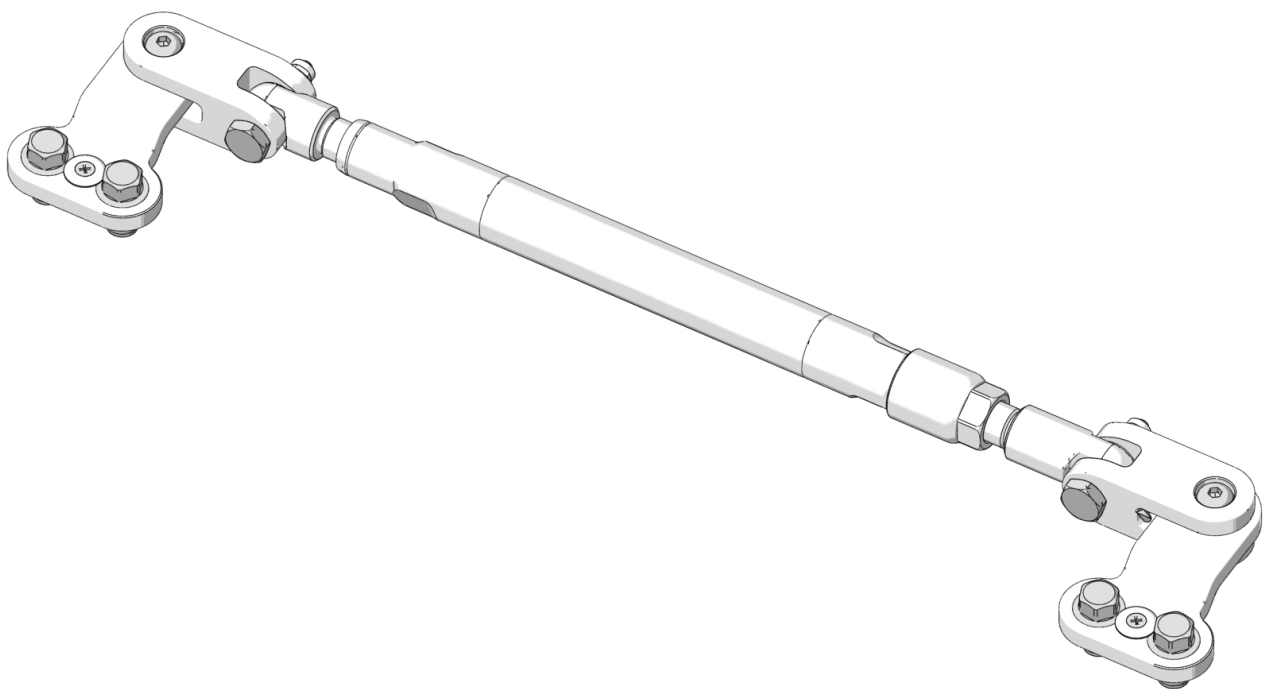

EN
page 2

ULTRAFLEX

IT
pag. 13

FR
page 25



PARTNER





Dear Customer,

We would like to thank you for choosing an **ULTRAFLEX** product.

ULTRAFLEX has been a leader in steering systems for pleasure and professional boats for many years. **ULTRAFLEX** production is since ever synonymous of reliability and safety.

All **ULTRAFLEX** products are designed and manufactured to ensure the best performance. To ensure your safety and to maintain a high quality level, **ULTRAFLEX** products are guaranteed only if they are used with original spare parts.

ULTRAFLEX and **UFLEX** Quality Management Systems are certified by the Det Norske Veritas - Germanischer Lloyd (DNV-GL), in conformity with the UNI EN ISO 9001:2015 rule.

The quality management system involves all the company resources and processes starting from the design, in order to:

- ensure product quality to the customer;
- maintain and improve the quality standards constantly;
- pursue a continuous process improvement to meet the market needs and to increase the customer satisfaction

ULTRAFLEX Environmental Management System is certified by the Det Norske Veritas - Germanischer Lloyd (DNV-GL), in conformity with the UNI EN ISO 14001:2015 rule.

Products for pleasure boats are constantly tested to check their conformity with the 2013/53/EU.



"**ULTRAFLEX** has over 80 years of experience in the marine industry and is a world leader in the production of mechanical, hydraulic and electronic steering systems, control boxes and steering wheels for any kind of pleasure, fishing or commercial boats.

The key factors which explain the increasing success of our products all over the world are the reliability of our products and the before and after sale service, the quality of the company organization and of the human resources and the continuous spending in research and development".

ULTRAFLEX S.p.A.

14015 Casella (Genova) Italia - Via Crose, 2

TABLE OF CONTENTS



DOCUMENT REVISIONS.....	4
USE OF THE MANUAL AND SYMBOLS USED.....	5
INFORMATIVE LETTER.....	6
WARRANTY.....	6

SECTION 1 - PRODUCT DESCRIPTION



1.1 GENERAL FEATURES.....	7
1.2 PACKAGING CONTENTS.....	7

SECTION 2 - INSTALLATION



2.1 NECESSARY TOOLS.....	8
2.2 A95 INSTALLATION.....	8
2.3 FINE ADJUSTMENT.....	10
2.4 ADJUSTMENT OF THE DISTANCE BETWEEN CENTERS WITH INSTALLED BAR.....	11

SECTION 3 - MAINTENANCE



3.1 ORDINARY MAINTENANCE.....	12
3.2 EXTRAORDINARY MAINTENANCE.....	12

SECTION 4 - DISMANTLING



4.1 DISMANTLING.....	12
----------------------	----

DOCUMENT REVISIONS











Rev.	Date	Revision description
0	05/10/2020	First edition

ENGLISH

USE OF THE MANUAL AND SYMBOLS USED

THE INSTALLATION AND MAINTENANCE MANUAL is the document accompanying the product from its sale to its replacement and discharge. The manual is an important part of the product itself. It is necessary to read carefully the manual, before ANY ACTIVITY involving the product, handling and unloading included.

In this manual the following symbols are used to ensure the user safety and to guarantee the correct operation of the product:

- 
DANGER

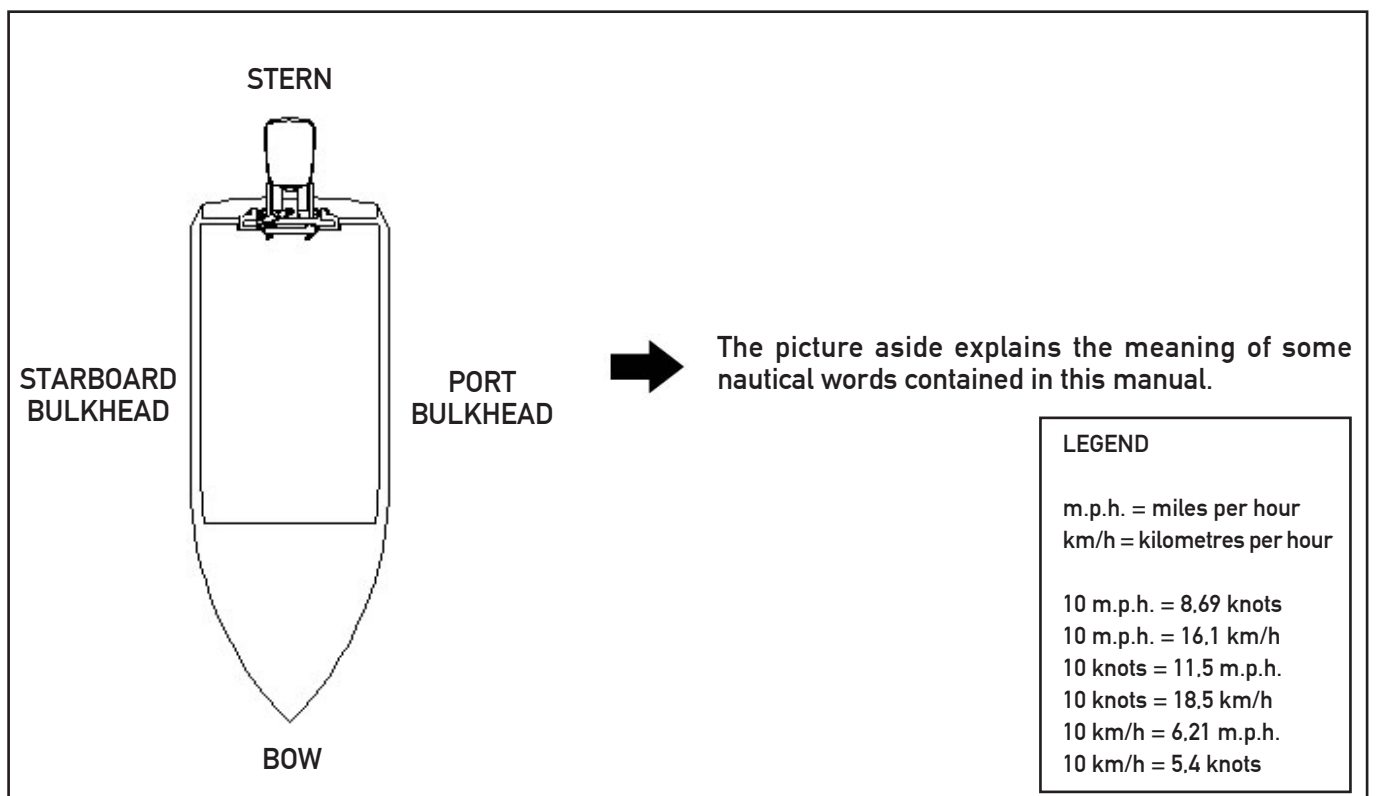
 Immediate hazards which CAUSE severe personal injury or death.
- 
WARNING

 Denotes that a hazard exists which can result in injury or death if proper precautions are not taken.
- 
CAUTION

 Denotes a reminder of safety practices or directs attention to unsafe practices which could result in personal injury or damage to the craft or components or to the environment.
- 
NOTE

 Important information for the correct installation and for maintenance, that does not cause any damage.
- 

 The symbol aside indicates all the operations which must be carried out by qualified or skilled staff, in order to avoid hazards. We recommend training the staff in charge of the product installation and checking their knowledge.



INFORMATIVE LETTER

This installation and maintenance manual represents an important part of the product and must be available to the people in charge of its use and maintenance.

The user must know the content of this manual.

ULTRAFLEX declines all responsibility for possible mistakes in this manual due to printing errors.

Apart from the essential features of the described product, **ULTRAFLEX** reserves the right to make those modifications, such as descriptions, details and illustrations, that are considered to be suitable for its improvement, or for design or sales requirements, at any moment and without being obliged to update this publication.

ALL RIGHTS ARE RESERVED. Publishing rights, trademarks, part numbers and photographs of **ULTRAFLEX** products contained in this manual are **ULTRAFLEX** property.

Great care has been taken in collecting and checking the documentation contained in this manual to make it as complete and comprehensible as possible. Nothing contained in this manual can be interpreted as warranty either expressed or implied - including, not in a restricted way, the suitability warranty for any special purpose. Nothing contained in this manual can be interpreted as a modification or confirmation of the terms of any purchase contract.

⚠ WARNING

To ensure the correct product and component operation, the product must be installed by qualified staff. In case of part damage or malfunction, please contact the qualified staff or our Technical Service.

TECHNICAL SERVICE

UFLEX S.r.l.

Via Milite Ignoto,8A

16012 Busalla (GE)-Italy

Tel: +39.010.962.01

Email: service@ultraflexgroup.it

www.ultraflexgroup.it

North - South - Central America:

UFLEX USA

6442 Parkland Drive

Sarasota, FL 34243

Tel: +1.941.351.2628

Email: sales@uflexusa.com

www.uflexusa.com

WARRANTY

ULTRAFLEX guarantees that its products are well designed and free from manufacturing and material defects, for a period of two years from the date of manufacturing.

For the products which are installed and used on working or commercial boats the warranty is limited to one year from the date of manufacturing.

If during this period the product proves to be defective due to improper materials and/or manufacture, the manufacturer will repair or replace the defective parts free of charge.

Direct or indirect damage is not covered by this warranty. In particular the company is not responsible and this warranty will not cover the damage resulting from incorrect installation or use of the product (except for replacement or repair of defective parts according to the conditions and terms above).

This warranty does not cover the products installed on race boats or boats used in competitions.

The descriptions and illustrations contained in this manual should be used as general reference only.

For any further information please contact our Technical Assistance Service.

ULTRAFLEX steering system components are marked **CE** according to the Directive 2013/53/EU.

We remind you that only **CE** marked steering systems must be used on the boats marked **CE**.

We inform you that the **ULTRAFLEX** warranty is null if some **ULTRAFLEX** components are installed on a steering system together with products of other brands.



1 PRODUCT DESCRIPTION

1.1 General features

The bar A95 is completely made up of stainless steel and it is already preassembled and ready to be installed. Its length can be adjusted: the distance between centers varies from 660 mm (26") to 812 mm (32") and from 812 mm (32") to 950 mm (37.5") according to the version (A95-32 and A95-37.5).

NOTE

The distance between the centers is calculated between the centers of the holes located in the engine tiller arms when the engines are parallel.

⚠ WARNING

It can be used in applications with dual outboard engine and dual UC130-SVS (or UC128-OBF and UC128-SVS) front mount cylinder

⚠ WARNING

Before the installation check the assembly compatibility of tie bar A95 with your application.

⚠ WARNING

Usually, the A95 bar allows to tilt the engines independently, the user must check it.

⚠ CAUTION

In dual cylinder applications it is necessary to order a cylinder with idler arm mounted on the starboard and a cylinder with idler arm mounted on the port.

⚠ WARNING

To allow the correct polymerization of the thread locker, wait 24 hours after the bar assembly before using it.

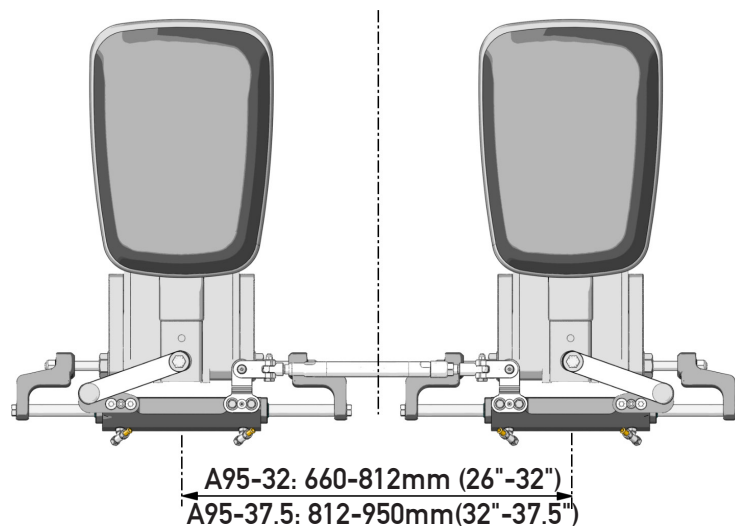

1.2 Packaging contents

1. Preassembled bar
2. Bag with screws

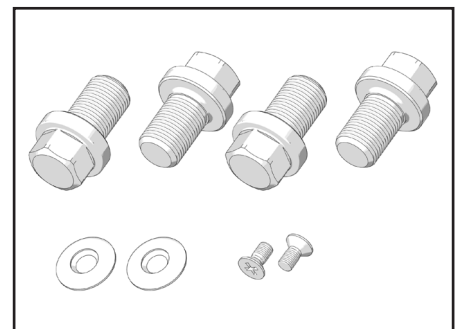
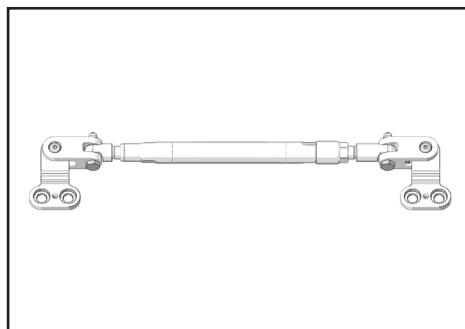

2 INSTALLATION

2.1 Necessary tools



14 mm hexagon wrench



2x 22 mm hexagon wrench



Dynamometric wrench



Cross slot screwdriver



Loctite® 270



4mm hex key

2.2 A95 Installation

- 1 Install the cylinders by carrying out the instructions indicated in the manual and positioning the engines as shown in the pictures indicated in point 2.

NOTE

Do not assemble the plugs on the cylinder body (see the picture aside).
If the plugs are already mounted, it is necessary to remove them.



- 2 Position the engines in the center of the stroke observing any convergence or divergence recommended by the engine manufacturers as shown in the picture aside (see the pictures below).

NOTE

With the same distance between centers of the engines, the "L" length of the bar will vary according to the chosen convergence or divergence angle.

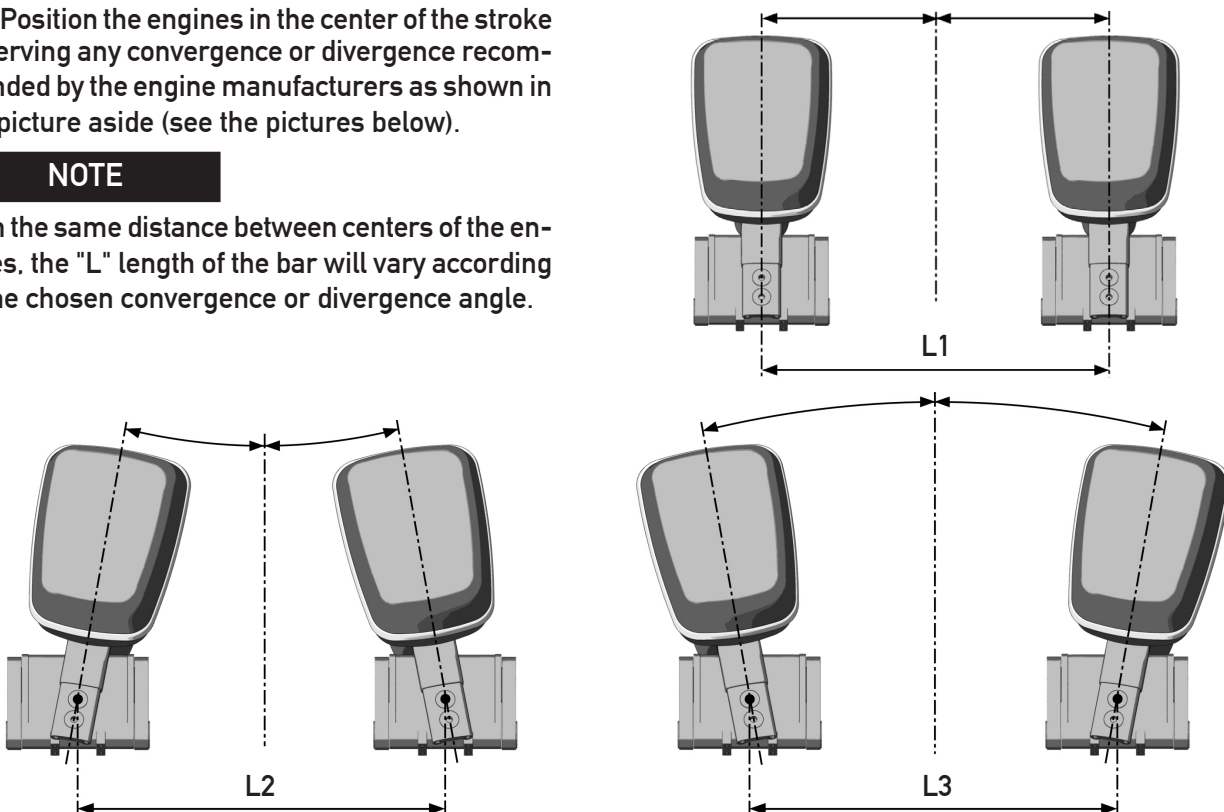

⚠ WARNING

When setting the convergence or divergence angle, follow the instructions given by the engine manufacturer, by imposing in any case and in any direction a total angle of no more than 5° and the difference between the measurements "A" (measurement of the distance between centers of the engines on the boat) and "B" (distance between the propeller shafts) of less than 1" (25.4 mm) (see picture).

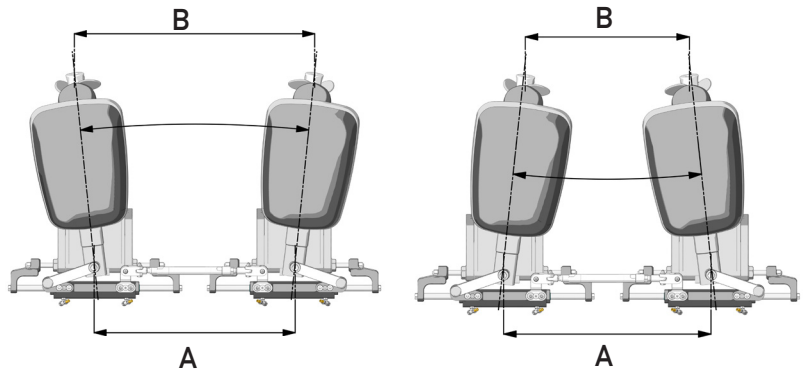

⚠ WARNING

Follow the engine adjustment procedure exactly.

3 Adjust the length of the bar by screwing and unscrewing the two ball joints (1) of the same size according to the distance between centers L1 of the engines.

DISTANCE BETWEEN CENTERS OF THE ENGINES	APPROXIMATE LENGTH OF THE BAR L
26"	455 mm (18")
27"	480 mm (19")
28"	508 mm (20")
29"	533 mm (21")
30"	559 mm (22")
31"	584 mm (23")
32"	608 mm (24")
34	660 mm (26")
36	711 mm (28")
37.5"	747 mm (29.5")

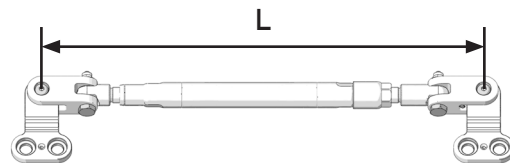
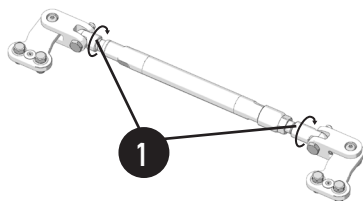

NOTE

It is possible to have a maximum extension of 76 mm (3") for each part with respect to A95-32; and an extension of 70 mm (2.75") with respect to A95-37.5.

⚠ WARNING

DO NOT FORCE THE UNSCREWING OF THE BAR'S END WHEN REACHING THE MAXIMUM EXTENSION.

⚠ DANGER

FORCING THE UNSCREWING OF THE BAR'S END WILL IRRETRIEVABLY DAMAGE THE BAR.

NOTE

Be careful not to damage the exposed thread: dents on the thread cause seizure of the parts.

NOTE

The correlation of the distance between centers is L2 or L3 and the bar length depends on the chosen divergence or convergence angle.



4 Assemble bracket (2) on the cylinder body (3) by means of the supplied screws (4). Tighten the screws with a 95 [Nm] (70 [lb-ft]) tightening torque by means of a 14mm wrench.

⚠ DANGER

Screw loosening causes deterioration and consequent ineffectiveness of the pre-applied thread locker. If the screws are loosened, they must be replaced.

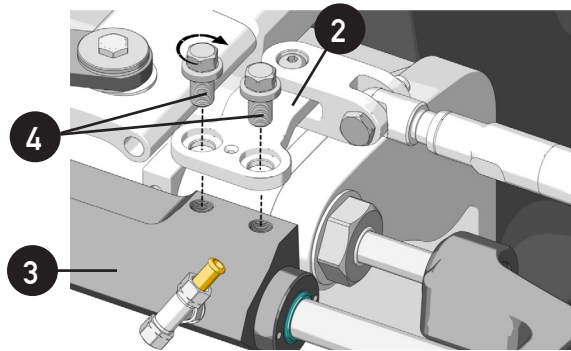

5 Position the safety washer (5) and fasten it with screw (6) applying some threadlocker like Loctite ®270 or similar with a 3[Nm] (2 [lb-ft]) tightening torque.

⚠ DANGER

The non-use of screw (6) and of safety washer (5) results in dangers to things and injury of people.

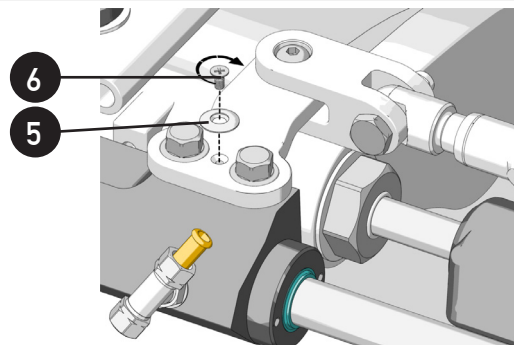

6 Tighten the dowels (8) pre-inserted in the bracket with a 24.6 Nm [18.14 lb-ft] tightening torque by means of a hex key (7).

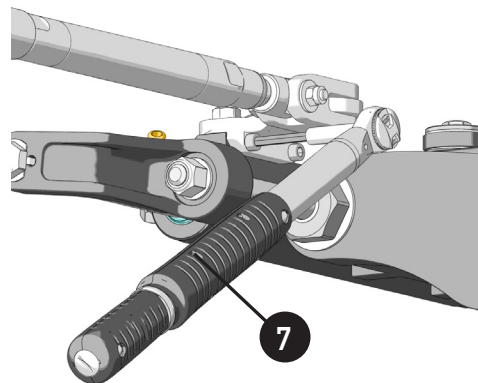
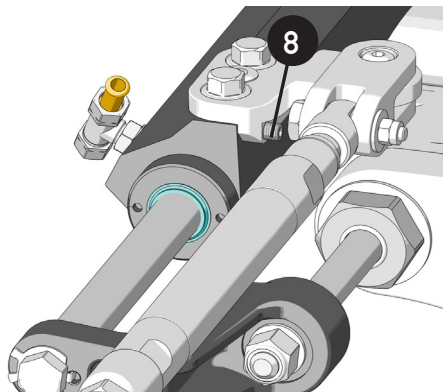

7 If necessary, proceed with the fine adjustment (paragraph 2.3) otherwise proceed directly to tighten the ring nut (step 2, paragraph 2.3).

⚠ DANGER

If the ring nut is not tightened while using the bar, this can cause damage to people or things.



2.3 Fine adjustment



After installation and before tightening the ring nut (1), it may be necessary to finely adjust the length of the bar in order to obtain the correct alignment of the engines.

- 1 Using a 22 mm wrench act on one of the end elements (3) or (2) and carry out the fine adjustment of the bar length.

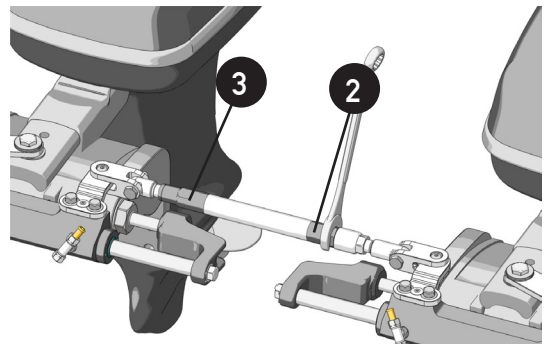

- 2 Once the fine adjustment has been carried out, tighten the ring nut (1) using a 22 mm wrench with a tightening torque of 40 [Nm] (29.52 [lb · ft]) by means of a second wrench on the end element (2).

⚠ WARNING

Check if the engine can also tilt independently and in different steering positions.

⚠ CAUTION

In no event shall the bar and/or its connections constitute a limitation to the steering allowed by the installed steering system and to the lifting of the engines.

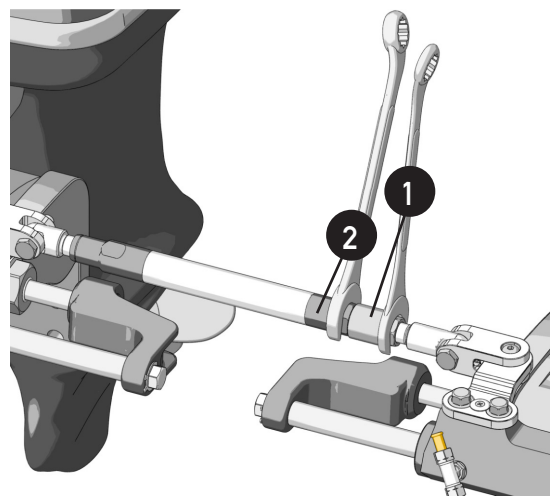

2.4 Adjustment of the distance between centers with installed bar



If during the use of the boat it is necessary to vary the distance between centers of the engines (i.e. the angle of divergence or convergence), proceed as follows.

⚠ WARNING

Before carrying out the following operations, it is mandatory to turn off the engines and operate in safe conditions.

- 1 By means of a 22 mm wrench loosen ring nut (1) holding it still with a second wrench on the end element (2).

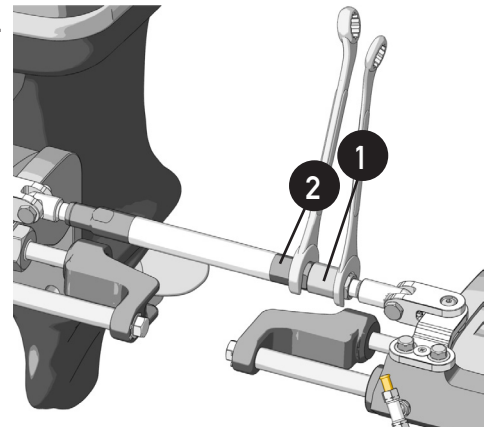

- 2 Proceed as shown on paragraph 2.3



3 MAINTENANCE

3.1 Ordinary maintenance

WARNING

Poor installation and maintenance may result in loss of steering and cause property damage and/or personal injury.

- 1 After the first 10 working hours and afterwards periodically check that the bar is intact and that the connections are tightened.

- A: 10 [Nm] (7,38 [lb·ft])
- B: 23 [Nm] (16,96 [lb·ft])
- C: 95 [Nm] (70 [lb·ft])
- D: 3 [Nm] (2 [lb·ft]).
- E: 40 [Nm] (29,52 [lb·ft])
- F: 24,6 [Nm] (18,14 [lb·ft])

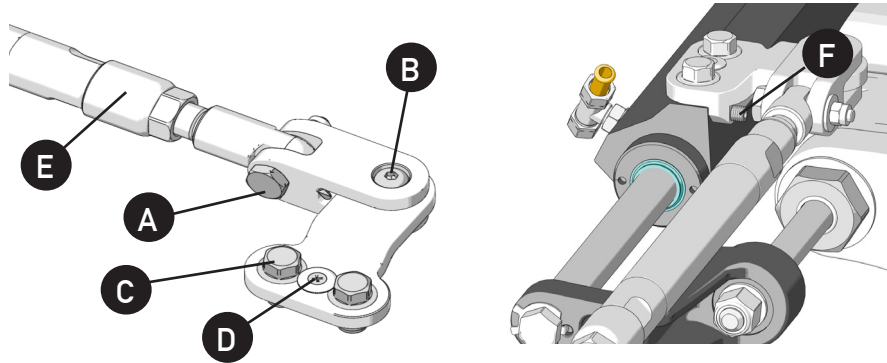

- 2 Periodically wash the components with fresh water in order to remove any salt deposits.

DANGER

In case of disassembly of the self-locking nuts and of the C and F elements (see the pictures above), they must be replaced. (please contact our technical service department).

3.2 Extraordinary maintenance

Technical service

For any information or for assistance with unusual applications please contact our technical support personnel (See paragraph "Introduction").

4 DISMANTLING

4.1 Dismantling

When for any reason, the system is put out of service, it is necessary to follow some rules in order to respect the environment.

Sheaths, pipelines, plastic or non-metallic components must be disassembled and disposed of separately.

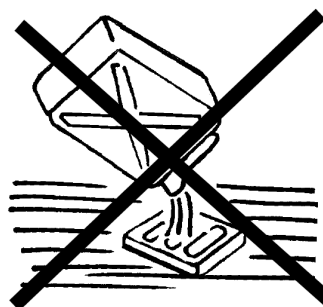

NOTES

ENGLISH

NOTES

ENGLISH

NOTES

ENGLISH

Manuale di installazione e manutenzione

BARRA D'ACCOPPIAMENTO

A95

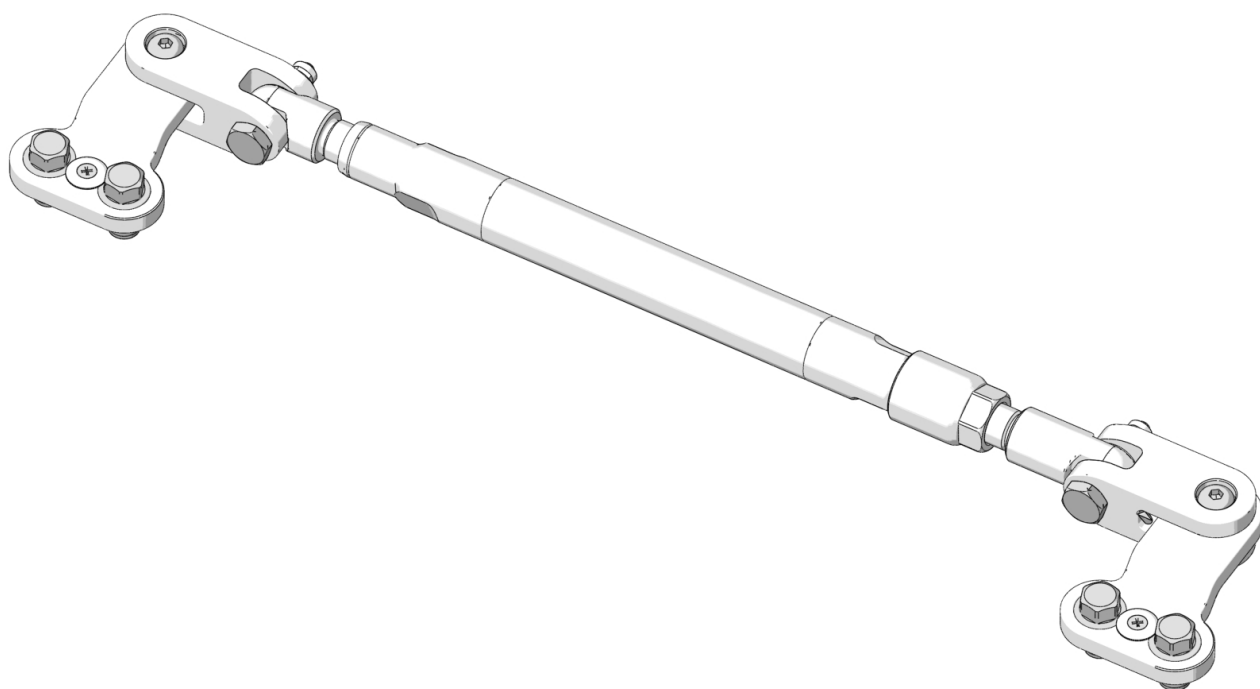

CE

 **ULTRAFLEX**





Gentile Cliente,

La ringraziamo per aver scelto un prodotto **ULTRAFLEX**.

ULTRAFLEX è da anni un punto di riferimento nei sistemi di guida nel settore della nautica da diporto e professionale.

Da sempre la produzione **ULTRAFLEX** è sinonimo di grande affidabilità e sicurezza.

Tutti i prodotti **ULTRAFLEX** sono progettati e prodotti per garantire sempre le prestazioni migliori, relativamente allo scopo per cui sono concepiti.

Per tutelare la Vostra sicurezza e per mantenere sempre un alto livello qualitativo **ULTRAFLEX** garantisce i propri prodotti solo se utilizzati con i ricambi originali.

I Sistemi di Gestione Qualità **ULTRAFLEX** ed **UFLEX** sono certificati dal DNV-GL Det Norske Veritas - Germanischer Lloyd, in conformità alla Norma UNI EN ISO 9001:2015.

Il sistema Qualità coinvolge tutte le risorse ed i processi aziendali a partire dalla progettazione, per:

- garantire al cliente la qualità del prodotto;
- impostare le azioni per mantenere e migliorare nel tempo gli standard di qualità;
- perseguire un continuo miglioramento dell'efficacia e dell'efficienza dei processi per poter essere sempre in sintonia con le esigenze del mercato ed accrescere la soddisfazione dei Clienti.

Il sistema di Gestione Ambientale **ULTRAFLEX** è certificato dal DNV-GL Det Norske Veritas - Germanischer Lloyd in conformità alla Norma UNI EN ISO 14001:2015.

I prodotti destinati alla nautica da diporto vengono costantemente controllati per verificare la rispondenza ai requisiti imposti dalla direttiva 2013/53/UE.



"**ULTRAFLEX**, con più di 80 anni di esperienza nel settore nautico è oggi leader globale nella produzione di sistemi di guida meccanici, idraulici ed elettronici, scatole di comando e volanti per imbarcazioni a motore da diporto, da pesca o da lavoro di ogni dimensione e tipo di motorizzazione.

L'affidabilità dei nostri prodotti ed il servizio ante e post vendita, la qualità dell'organizzazione aziendale e delle risorse umane insieme agli investimenti continui in ricerca e sviluppo sono fattori determinanti per spiegare il successo crescente dei nostri prodotti ovunque nel mondo".

ULTRAFLEX S.p.A.

16015 Casella (Genova) Italia - Via Crose, 2

INDICE GENERALE



INDICE DELLE REVISIONI DEL DOCUMENTO.....	20
USO DEL MANUALE E SIMBOLOGIA IMPIEGATA	21
LETTERA INFORMATIVA.....	22
GARANZIA	22

SEZIONE 1 - DESCRIZIONE DEL PRODOTTO



1.1 CARATTERISTICHE GENERALI.....	23
1.2 CONTENUTO IMBALLO.....	23

SEZIONE 2 - INSTALLAZIONE



2.1 UTENSILI NECESSARI.....	24
2.2 INSTALLAZIONE A95	24
2.3 REGOLAZIONE FINE.....	26
2.4 REGOLAZIONE INTERASSE CON BARRA INSTALLATA.....	27

SEZIONE 3 - MANUTENZIONE



3.1 MANUTENZIONE ORDINARIA.....	28
3.2 MANUTENZIONE STRAORDINARIA.....	28

SEZIONE 4 - SMANTELLAMENTO



4.1 SMANTELLAMENTO	28
--------------------------	----



INDICE DELLE REVISIONI DEL DOCUMENTO

Rev.	Data	Descrizione della revisione
0	05/10/2020	Prima realizzazione

USO DEL MANUALE E SIMBOLOGIA IMPIEGATA

IL MANUALE DI INSTALLAZIONE E MANUTENZIONE è il documento che accompagna il prodotto dal momento della sua vendita fino alla sua sostituzione e smaltimento. Risulta cioè essere parte integrante dello stesso. E' richiesta la lettura del manuale prima che venga intrapresa QUALSIASI ATTIVITA' che coinvolga il prodotto compresa la movimentazione e lo scarico dello stesso dal mezzo di trasporto.

Al fine di tutelare la sicurezza dell'utilizzatore e per garantire il corretto funzionamento del prodotto nel presente manuale è stata adottata la simbologia di seguito descritta.

-  **PERICOLO** → Danni immediati che CAUSANO ferite gravi alla persona o che portano alla morte.
-  **AVVERTENZA** → Indica che esiste un pericolo che può causare lesione o morte se non sono adottate le precauzioni appropriate.
-  **ATTENZIONE** → Indica un richiamo all'applicazione di pratiche di sicurezza oppure richiama l'attenzione su pratiche non sicure che potrebbero causare lesione personale o danno all'imbarcazione o ai componenti o all'ambiente.
-  **NOTA** → Informazione ritenuta importante per una installazione adeguata e per la manutenzione, che non è causa di danni.
-  → Le operazioni per la cui esecuzione si richiede, onde evitare possibili rischi, personale qualificato o specializzato sono evidenziate con il simbolo indicato a lato. Si raccomanda di formare il personale destinato all'installazione del prodotto e di verificare che quanto previsto sia compreso ed attuato.

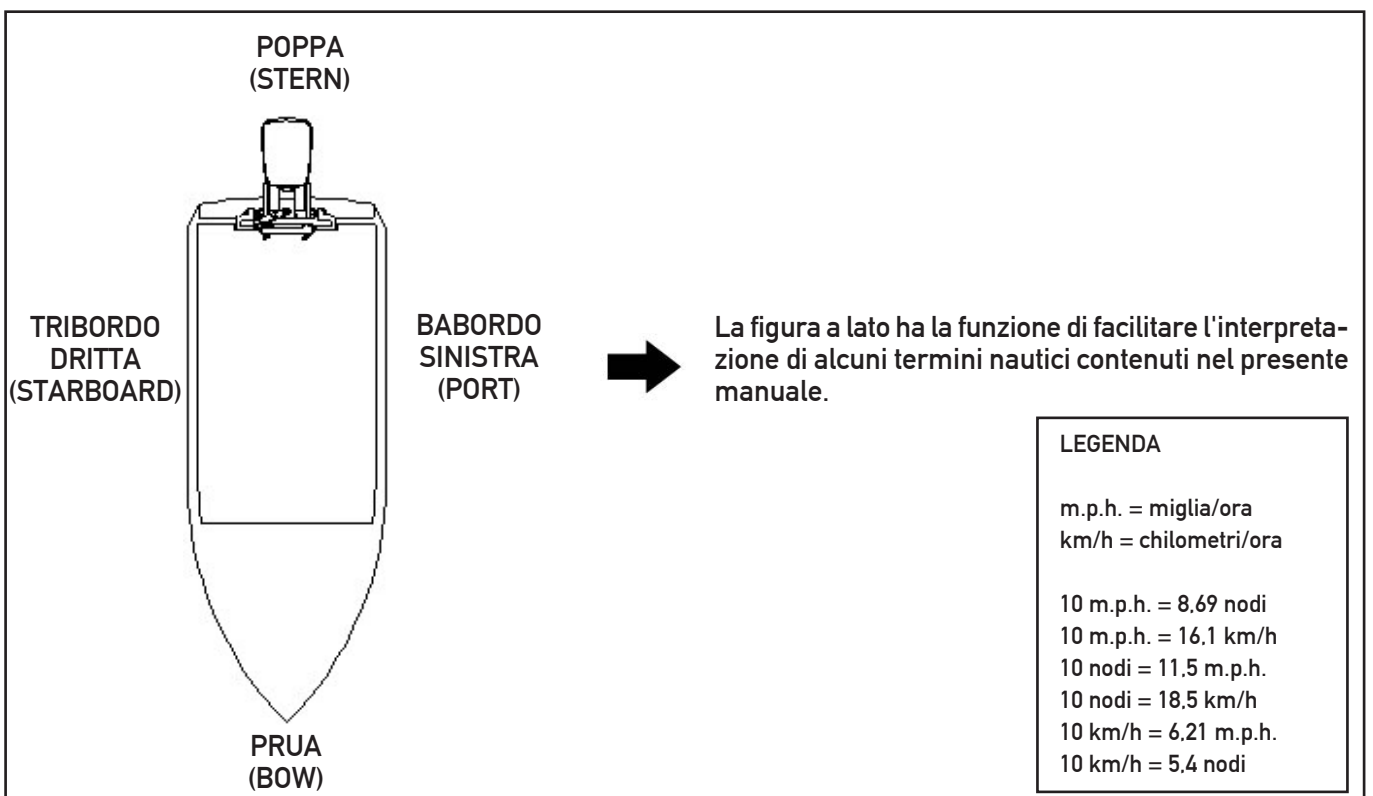

ITALIANO



LETTERA INFORMATIVA

Il presente manuale di installazione e manutenzione costituisce parte integrante del prodotto e deve essere facilmente reperibile dal personale addetto all'uso e alla manutenzione dello stesso.

L'utilizzatore è tenuto a conoscere il contenuto del presente manuale.

ULTRAFLEX declina ogni responsabilità per eventuali inesattezze dovute ad errori di stampa, contenute nel manuale. Ferme restando le caratteristiche essenziali del prodotto descritto, **ULTRAFLEX** si riserva il diritto di apportare eventuali modifiche di descrizioni, dettagli e illustrazioni, che riterrà opportuno per il miglioramento dello stesso, o per esigenze di carattere costruttivo o commerciale, in qualunque momento e senza impegnarsi ad aggiornare tempestivamente questa pubblicazione.

TUTTI I DIRITTI SONO RISERVATI. I diritti di pubblicazione, i marchi, le sigle e le fotografie dei prodotti **ULTRAFLEX** presenti in questo manuale sono di proprietà **ULTRAFLEX** che ne vieta qualsiasi riproduzione anche parziale. Ogni cura è stata posta nella raccolta e nella verifica della documentazione per rendere questo manuale il più completo e comprensibile possibile. Nulla di quanto contenuto nella presente pubblicazione può essere interpretato come garanzia o condizione espressa o implicita - inclusa, non in via limitativa, la garanzia di idoneità per un particolare scopo. Nulla di quanto contenuto nella presente pubblicazione può inoltre essere interpretato come modifica o asserzione dei termini di qualsivoglia contratto di acquisto.

AVVERTENZA

Al fine di assicurare il corretto funzionamento del prodotto e dei suoi componenti, lo stesso deve essere installato da personale esperto. In caso di rotture di parti componenti o malfunzionamento, rivolgersi al personale specializzato o contattare il nostro Servizio Assistenza Tecnica.

SERVIZIO ASSISTENZA TECNICA

UFLEX S.r.l.

Via Milite Ignoto,8A

16012 Busalla (GE)-Italia

Tel: +39.010.962.01

Email: service@ultraflexgroup.it

www.ultraflexgroup.it

Nord - Sud - Centro America:

UFLEX USA

6442 Parkland Drive

Sarasota, FL 34243

Tel: +1.941.351.2628

Email: sales@uflexusa.com

www.uflexusa.com

GARANZIA

ULTRAFLEX garantisce che i suoi prodotti sono costruiti a regola d'arte e che sono privi di difetti di fabbricazione e di materiali.

Questa garanzia è valida per un periodo di due anni decorrenti dalla data di fabbricazione dei prodotti ad eccezione dei casi in cui questi siano installati ed usati su barche da lavoro o comunque su barche ad utilizzo commerciale, nel qual caso la garanzia è limitata ad 1 anno dalla data di fabbricazione.

Questa garanzia è limitata alla sostituzione o riparazione gratuita del pezzo che, entro il termine suddetto, ci sarà restituito in porto franco e che rileveremo essere effettivamente difettoso nei materiali o/e nella fabbricazione.

È escluso dalla garanzia ogni e qualsiasi altro danno diretto o indiretto. In particolare, è escluso dalla garanzia e da ogni nostra responsabilità (tranne quella di sostituire o riparare, nei termini e condizioni suddette, i pezzi difettosi) il malfunzionamento dei nostri prodotti qualora il loro mancato o difettoso funzionamento sia attribuibile ad una errata installazione o ad uso negligente o improprio.

Questa garanzia non copre i prodotti installati su barche da corsa o utilizzate in contesti competitivi. Le descrizioni e le illustrazioni di questo manuale s'intendono fornite a titolo indicativo.

Per informazioni dettagliate si prega di contattare il nostro Servizio Assistenza.

I componenti dei sistemi di guida **ULTRAFLEX** sono marcati **CE** come richiesto dalla direttiva 2013/53/UE.

Vi ricordiamo che sulle imbarcazioni marcate **CE** è obbligatorio installare sistemi di guida i cui componenti siano marcati **CE**. Vi informiamo che la garanzia **ULTRAFLEX** decade automaticamente qualora alcuni componenti **ULTRAFLEX** siano installati in un sistema di guida insieme a prodotti di altre marche.



1 DESCRIZIONE DEL PRODOTTO

1.1 Caratteristiche generali

La barra A95 è costruita interamente in acciaio inossidabile ed è fornita già preassemblata, pronta per l'installazione. La lunghezza è regolabile: gli interassi variano da 660 mm (26") a 812 mm (32") e da 812 mm (32") a 950 mm (37.5") a seconda della versione (A95-32 e A95-37.5).

NOTA

Per interasse si intende la distanza tra i centri dei fori presenti sui bracci dei motori quando questi ultimi sono paralleli.

⚠ AVVERTENZA

È utilizzabile nelle applicazioni con doppio motore fuoribordo e doppio UC130-SVS (o UC128-OBF e UC128-SVS) a montaggio frontale.

⚠ AVVERTENZA

Prima di iniziare l'installazione, riverificare la compatibilità di montaggio della barra A95 con la vostra applicazione.

⚠ AVVERTENZA

Normalmente, la barra A95 permette il tiltaggio indipendente dei motori, è compito dell'utente la verifica.

⚠ ATTENZIONE

Nelle applicazioni con doppio cilindro è necessario ordinare un cilindro con braccio di rinvio montato a destra (starboard) e un cilindro con braccio di rinvio montato a sinistra (port).

⚠ AVVERTENZA

Per permettere la corretta polimerizzazione dei frenafili, aspettare 24 ore dopo l'assemblaggio della barra prima dell'utilizzo.

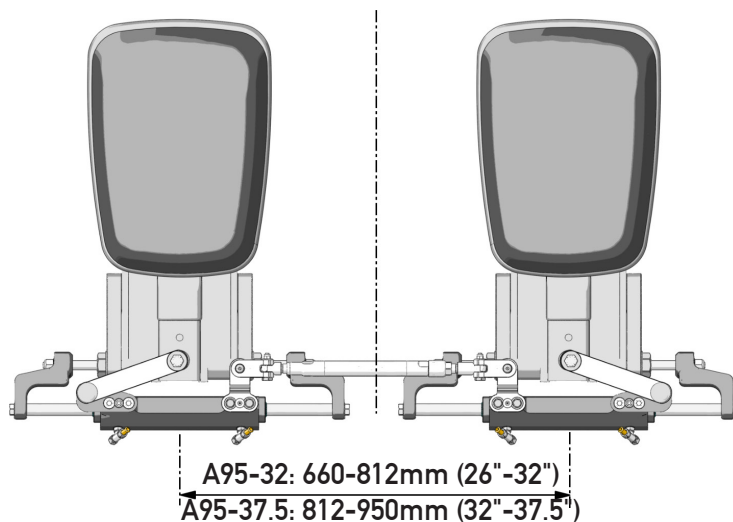

1.2 Contenuto dell'imballo

1. Barra preassemblata
2. Sacchetto con viterie

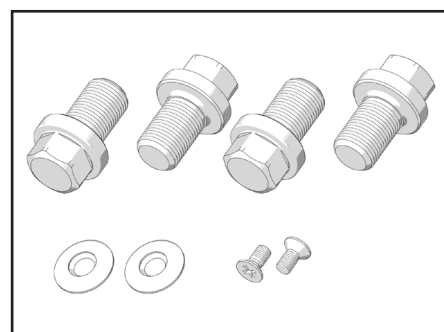
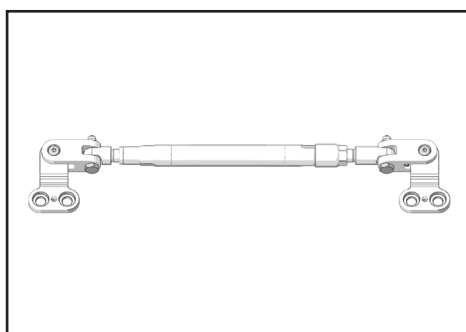

2 INSTALLAZIONE

2.1 Utensili necessari



Chiave esagonale 14 mm



2x Chiave esagonale 22 mm



Chiave dinamometrica



Cacciavite a croce



Loctite® 270



Chiave a brugola con esagono da 4 mm

2.2 Installazione A95

1 Installare i cilindri seguendo le istruzioni fornite all'interno del relativo manuale e posizionando i motori come nelle figure riportate al punto 2.

NOTA

Non montare i tappi in dotazione sul corpo del cilindro (vedi figura a lato). Nel caso in cui i tappi fossero già montati occorre rimuoverli.

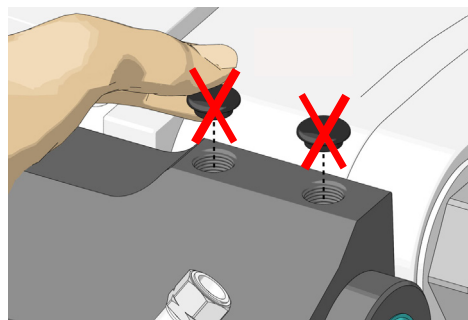

2 Posizionare i motori al centro della corsa come mostrato nella figura a lato, rispettando l'eventuale convergenza o divergenza raccomandata dai costruttori dei motori (vedi figure sotto).

NOTA

A parità di interasse tra i motori, la lunghezza "L" della barra varierà in funzione dell'angolo di convergenza o divergenza scelto.

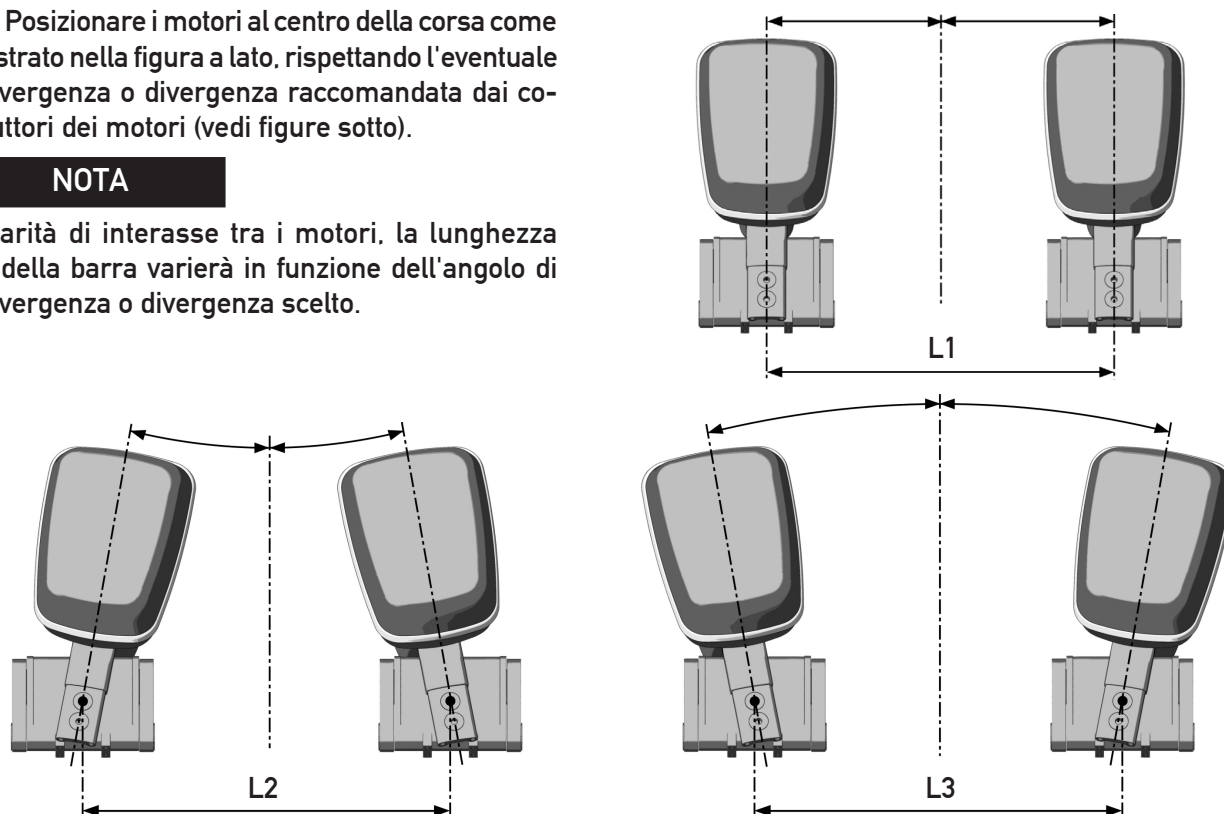

⚠ AVVERTENZA

Nell'impostare l'angolo di convergenza o divergenza seguire quanto indicato dal motorista, imponendo in ogni caso e in qualunque direzione un angolo totale non superiore a 5° e la differenza tra le misure "A" (misura dell'interasse tra i motori sulla barca) e "B" (distanza tra gli assi delle eliche) inferiore a 1" (25.4 mm) (vedere figura).

⚠ AVVERTENZA

Seguire pedissequamente la procedura di regolazione dei motori.

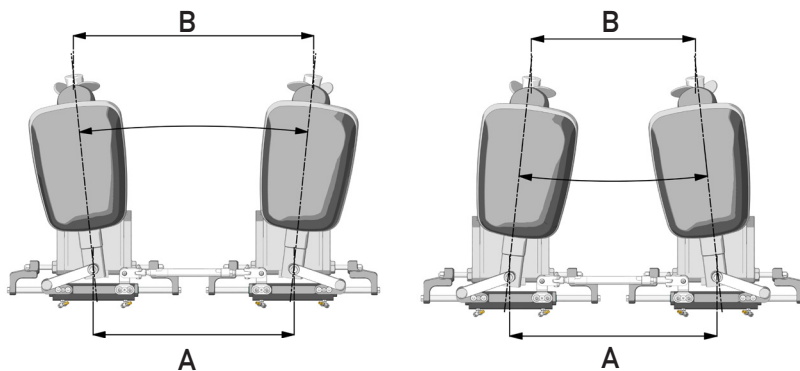

3 Regolare la lunghezza della barra avvitando e svitando i due puntali (1) della stessa misura in base all'interasse L1 dei motori.

INTERASSE MOTORI	LUNGHEZZA INDICATIVA DELLA BARRA L
26"	455 mm (18")
27"	480 mm (19")
28"	508 mm (20")
29"	533 mm (21")
30"	559 mm (22")
31"	584 mm (23")
32"	608 mm (24")
34	660 mm (26")
36	711 mm (28")
37.5"	747 mm (29.5")

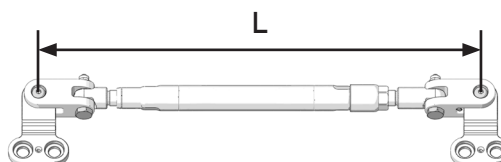
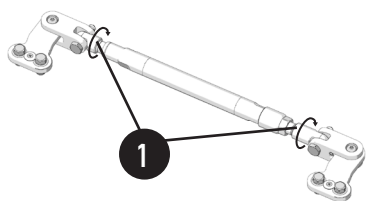

NOTA

Si può ottenere al massimo una estensione di 76 mm (3") per parte nel caso dell'A95-32; di 70 mm (2.75") nel caso dell'A95-37.5

⚠ AVVERTENZA

NON FORZARE LO SVITAMENTO DEI PUNTALI AL RAGGIUNGIMENTO DELLA MASSIMA ESTENSIONE .

⚠ PERICOLO

FORZARE LO SVITAMENTO DEI PUNTALI DANNEGGERÀ IRREPARABILMENTE LA BARRA.

NOTA

Fare attenzione a non danneggiare la filettatura esposta: ammaccature sulla filettatura provocano grippaggio delle parti.

NOTA

La correlazione tra gli interassi L2 o L3 e la lunghezza della barra dipende dall'angolo di divergenza o convergenza scelto.



4 Montare la staffa (2) sul corpo cilindro (3) utilizzando le viti in dotazione (4). Serrare le viti con una coppia di serraggio di 95 [Nm] (70 [lb-ft]) mediante una chiave aperta da 14mm.

⚠ PERICOLO

Il disserraggio delle viti provoca deterioramento e conseguente inefficacia del frenafili pre-applicato. In caso di disserraggio delle viti, queste ultime devono essere sostituite.

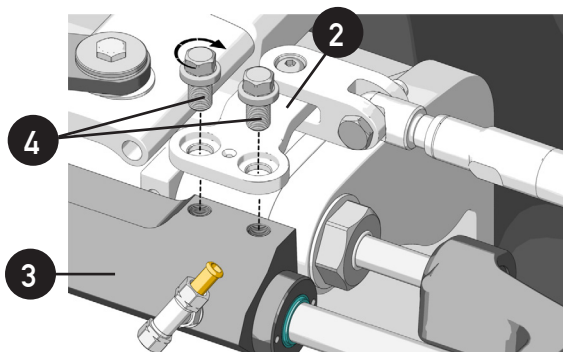

5 Posizionare la rondella di sicurezza (5) e bloccarla con la vite (6) applicando frenafili tipo Loctite®270 o equivalente con coppia di serraggio 3[Nm] (2 [lb-ft]).

⚠ PERICOLO

Il mancato utilizzo della vite (6) e della rondella di sicurezza (5) provoca danni a persone o cose.

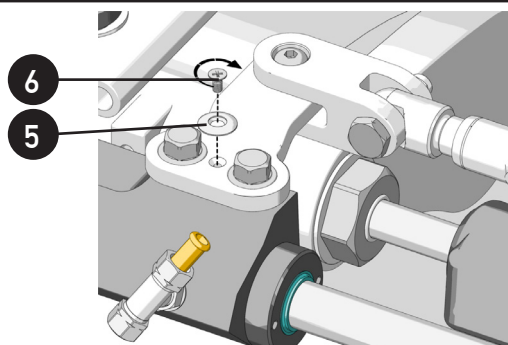

6 Serrare con la chiave a brugola (7) i grani (8) preinseriti nella staffa con coppia di serraggio 24,6 Nm [18,14 lb-ft].

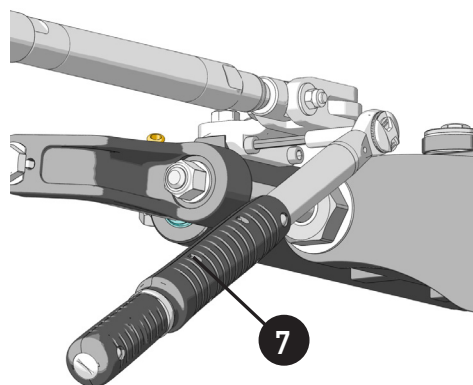
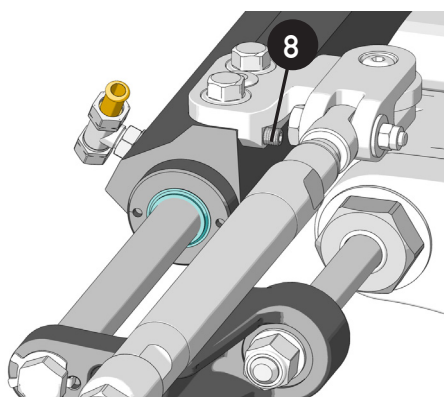

7 Procedere, se necessario, con la regolazione fine (paragrafo 2.3) altrimenti procedere direttamente a stringere le ghiera (punto 2, paragrafo 2.3).

⚠ PERICOLO

Il mancato serraggio della ghiera durante l'utilizzo della barra provoca danni a persone o cose.



2.3 Regolazione fine



Dopo l'installazione e prima di aver serrato la ghiera (1), potrebbe essere necessario regolare finemente la lunghezza della barra al fine di ottenere il corretto allineamento dei motori.

- 1 Agendo con una chiave da 22 mm su uno degli elementi di estremità (2) o (3) procedere con la regolazione fine della lunghezza della barra.

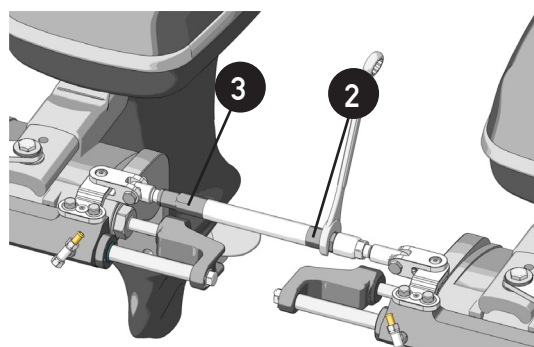

- 2 Una volta effettuata la regolazione fine, stringere la ghiera (1) utilizzando una chiave da 22 mm con una coppia di serraggio di 40[Nm] (29.52 [lb-ft]) aiutandosi con una seconda chiave sull'elemento di estremità (2).

⚠ AVVERTENZA

Verificare la possibilità di tiltaggio del motore, anche in modo indipendente e in diverse posizioni di sterzata.

⚠ ATTENZIONE

In nessun caso la barra e/o le connessioni della stessa dovranno costituire una limitazione alla sterzata consentita dal sistema di guida installato ed al sollevamento dei motori stessi.

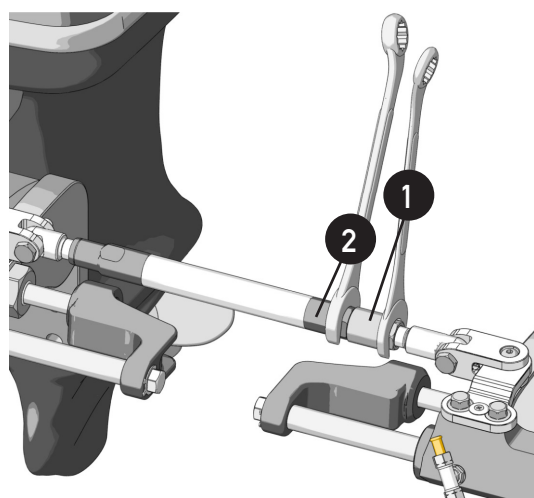

2.4 Regolazione interasse con barra installata



Se durante l'utilizzo dell'imbarcazione dovesse nascere la necessità di variare l'interasse dei motori (ovvero l'angolo di divergenza o convergenza), procedere come segue.

⚠ AVVERTENZA

Prima di procedere con le seguenti operazioni, è obbligatorio spegnere i motori e operare in condizioni di sicurezza.

- 1 Allentare la ghiera (1) con una chiave da 22 mm tenendola ferma con una seconda chiave sull'elemento di estremità (2).

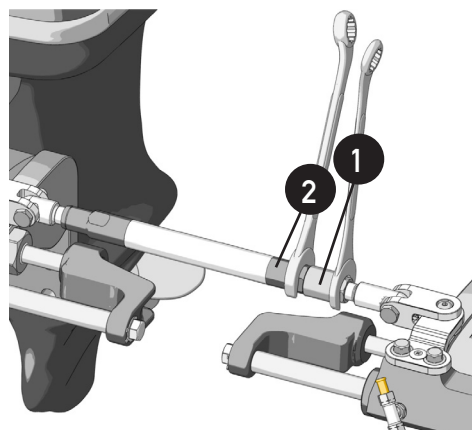

- 2 Procedere come illustrato nel paragrafo 2.3.



3 MANUTENZIONE

3.1 Manutenzione ordinaria

AVVERTENZA

La mancata osservanza dei controlli di manutenzione può causare la perdita di guida con possibili danni materiali e/o lesioni personali.

- 1 Verificare dopo le prime 10 ore di uso ed in seguito periodicamente l'integrità della barra ed il serraggio delle connessioni.

- A: 10 [Nm] (7,38 [lb-ft])
- B: 23 [Nm] (16,96 [lb-ft])
- C: 95 [Nm] (70 [lb-ft])
- D: 3 [Nm] (2 [lb-ft]).
- E: 40 [Nm] (29,52 [lb-ft])
- F: 24,6 [Nm] (18,14 [lb-ft])

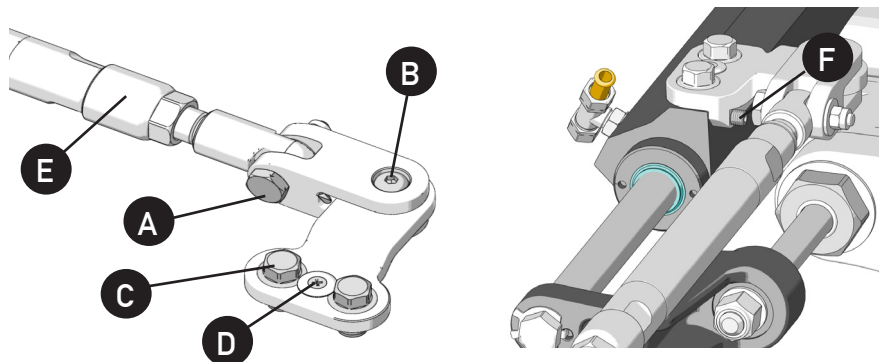

- 2 Periodicamente lavare con acqua dolce i componenti per rimuovere eventuali depositi di sale.

PERICOLO

Nel caso di smontaggio dei dadi autobloccanti e degli elementi C e F (vedi figure sopra), questi ultimi dovranno essere sostituiti. (Contattare il nostro servizio assistenza).

3.2 Manutenzione straordinaria

Assistenza tecnica

Per qualsiasi informazione o per assistenza relativa ad applicazioni particolari, Vi invitiamo a contattare il nostro servizio di assistenza tecnica (Vedi paragrafo "Lettera informativa").

4 SMANTELLAMENTO

4.1 Smantellamento

Qualora si intenda, per qualsiasi motivo, mettere fuori servizio la barra di accoppiamento, è necessario osservare alcune regole fondamentali atte a salvaguardare l'ambiente.

Guaine, condotti flessibili, componenti di materiale plastico o comunque non metallico, dovranno essere smontati e smaltiti separatamente.



RECYCLE
BECACTE

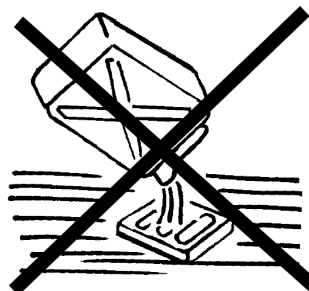

Manuel d'installation et d'entretien

BARRE D'ACCOUPLLEMENT

A95

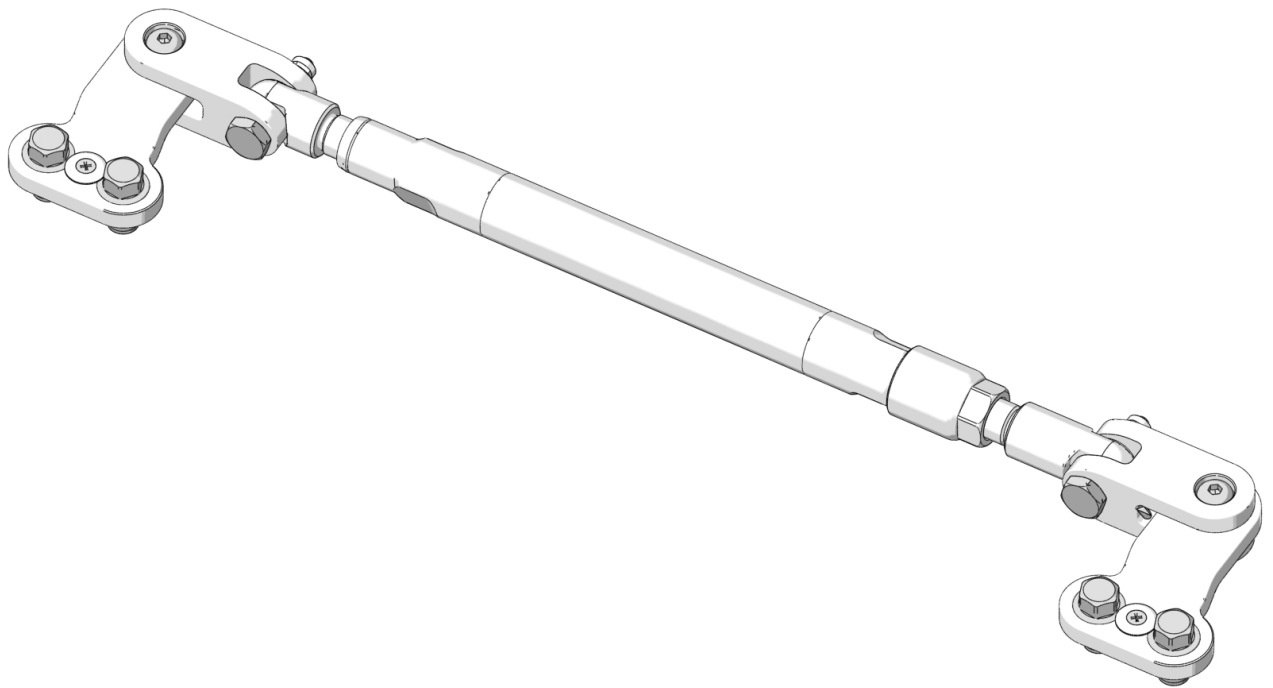

CE



ULTRAFLEX



ASSOCIE

MEMBER
ABYC
Setting Standards for Safer Boating®





Cher Client,

Nous vous remercions pour avoir choisi un produit **ULTRAFLEX**.

La Société **ULTRAFLEX** est depuis plusieurs années un point de repère dans les systèmes de gouvernement dans le domaine de la navigation de plaisance et professionnelle.

La production **ULTRAFLEX** est depuis toujours une garantie de grande fiabilité et sécurité.

Tous les produits **ULTRAFLEX** sont conçus et fabriqués pour assurer toujours les performances les meilleures. Pour assurer votre sécurité et pour maintenir toujours un niveau de qualité élevé **ULTRAFLEX** ne garantit ses produits que si les pièces de rechange originales sont utilisées (voir annexe "Application Spare Parts").

Les Systèmes de Gestion de la Qualité **ULTRAFLEX** et **UFLEX** sont certifiés par le Det Norske Veritas - Germanischer Lloyd (DNV-GL), en conformité avec la Norme UNI EN ISO 9001:2015.

Le système Qualité implique toutes les ressources et les processus d'entreprise à partir de la conception du projet au but de:

- assurer au client la qualité du produit;
- maintenir et améliorer continuellement les standard de qualité;
- poursuivre une amélioration continue de l'efficacité des processus afin de répondre toujours aux exigences du marché et d'augmenter la satisfaction des Clients;

Le système de Gestion Environnementale de la Qualité **ULTRAFLEX** est certifié par le Det Norske Veritas - Germanischer Lloyd (DNV-GL), en conformité avec la Norme UNI EN ISO 14001:2015.

Vérifier la conformité des produits aux prescriptions de la directive 2013/53/EU.



"**ULTRAFLEX** avec plus de 80 années d'expérience dans le domaine nautique, est aujourd'hui une industrie de pointe sur échelle mondiale dans la production de systèmes de gouvernement mécaniques, hydrauliques, électroniques, boîtes de commande et volants pour bateaux moteur pour la plaisance, la pêche ou le travail de toutes les dimensions et types de motorisations.

La fiabilité de nos produits et le service pré-vente et après-vente, la qualité de l'organisation de l'entreprise et des ressources humaines aussi bien que les investissements continus dans la recherche et le développement sont des facteurs fondamentaux pour expliquer le succès croissant de nos produits dans le monde entier".

ULTRAFLEX S.p.A.

16015 Casella (Genova) Italia - Via Crose, 2

INDEX GENERAL



INDEX DES REVISIONS DU DOCUMENT.....	36
EMPLOI DU MANUEL ET SYMBOLES UTILISES.....	37
LETTRE D'INFORMATION	38
GARANTIE	38

SECTION 1 - DESCRIPTION DU PRODUIT



1.1 CARACTERISTIQUES GENERALES	39
1.2 CONTENU EMBALLAGE	39

SECTION 2 -INSTALLATION



2.1 OUTILS NECESSAIRES	40
2.2 INSTALLATION A95	40
2.3 REGLAGE FIN	42
2.4 REGLAGE DISTANCE ENTRE-AXES AVEC BARRE INSTALLEE	43

SECTION 3 - ENTRETIEN



3.1 ENTRETIEN ORDINAIRE	44
3.2 ENTRETIEN EXTRAORDINAIRE.....	44

SECTION 4 - DEMOLITION



4.1 DEMOLITION.....	44
---------------------	----

INDEX DES REVISIONS DU DOCUMENT

Rév.	Date	Description de la révision
0	05/10/2020	Première réalisation

EMPLOI DU MANUEL ET SYMBOLES UTILISES

Le MANUEL D'INSTALLATION ET D'ENTRETIEN est le document qui accompagne le produit de sa vente jusqu'à son remplacement et sa démolition. C'est donc une partie fondamentale du produit lui-même.

Il faut lire le manuel avant TOUTE ACTIVITE concernant le produit y compris sa manutention et son déchargement du moyen de transport.

Les symboles ci-dessous ont été adoptés dans le manuel afin d'assurer la sécurité de l'usager et le fonctionnement correct du produit:

⚠ DANGER → Dommages immédiats qui CAUSENT des blessures graves à la personne ou qui en provoquent la mort.

⚠ AVERTISSEMENT → Il indique qu'il y a un danger qui peut provoquer des lésions ou la mort si on n'adoptent pas les précautions appropriées.

⚠ ATTENTION → Il indique un appel à l'application de pratiques de sécurité ou il appelle l'attention sur des pratiques non sûres qui pourraient causer des lésions personnelles ou des dommages au bateau ou aux composants ou à l'environnement.

NOTE → Information importante pour une installation adéquate et pour l'entretien, qui ne cause pas de dommages.

 → Les opérations pour l'exécution desquelles on demande du personnel qualifié ou spécialisé, afin d'éviter toute sorte de risques, sont indiquées avec le symbole à côté. On recommande de former le personnel préposé à l'installation du produit et de vérifier si ce qui est prévu a été compris et mis en oeuvre.

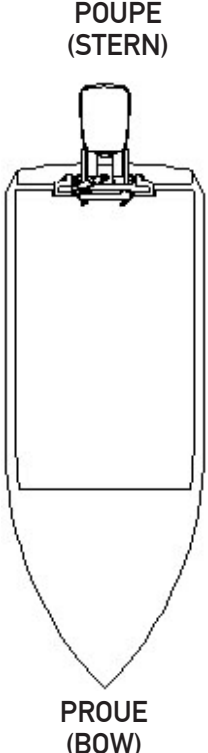

POUPE
(STERN)

TRIBORD
(STARBOARD)

BABORD
(PORT)

PROUE
(BOW)

→ La figure à côté peut guider l'interprétation de certains termes nautiques contenus dans ce manuel.

LEGENDE

m.p.h. = milles par heure
km/h = kilomètres par heure

10 m.p.h. = 8,69 noeuds
10 m.p.h. = 16,1 km/h
10 noeuds = 11,5 m.p.h.
10 noeuds = 18,5 km/h
10 km/h = 6,21 m.p.h.
10 km/h = 5,4 noeuds

FRANÇAIS



LETTRÉ D'INFORMATION

Ce manuel d'installation et d'entretien est une partie intégrante du produit et il doit être facilement repérable par le personnel préposé à son emploi et à son entretien. L'utilisateur doit connaître le contenu de ce manuel.

La Société **ULTRAFLEX** décline toute responsabilité en cas d'inexactitudes dues à des fautes d'impression, contenues dans le manuel. Bien que les caractéristiques principales du type de produit décrit ne changent pas, la Société **ULTRAFLEX** se réserve le droit de modifier les descriptions, les détails et les illustrations qu'elle jugera nécessaires afin de l'améliorer, soit pour des exigences de caractère constructif ou commercial, dans n'importe quel moment et sans être obligé de mettre à jour le manuel tout de suite.

TOUS LES DROITS SONT RESERVES. Les droits de publication, les marques, les sigles et les photos des produits **ULTRAFLEX** contenus dans ce manuel appartiennent à la Société **ULTRAFLEX** qui en interdit toute sorte de reproduction même partielle. Tous les soins ont été pris pour rassembler et contrôler la documentation contenue dans ce manuel afin de le rendre le plus complet et le plus compréhensible possible. Rien de ce qui est contenu dans cette publication ne peut être interprété comme garantie ou condition explicite ou implicite - y compris, pas en voie limitative, la garantie d'aptitude pour un but particulier. Rien de ce qui est contenu dans cette publication ne peut être interprété comme modification ou assertion des termes de n'importe quel contrat d'achat.

⚠ AVERTISSEMENT

Le produit doit être installé par du personnel formé afin d'assurer son fonctionnement correct et celui de ses composants. En cas de rupture de parties ou de mauvais fonctionnement, s'adresser au personnel spécialisé ou contacter notre Service d'Assistance Technique.

SERVICE D'ASSISTANCE TECHNIQUE

UFLEX S.r.l.

Via Milite Ignoto,8A

16012 Busalla (GE)-Italia

Tel: +39.010.962.01

Email: service@ultraflexgroup.it

www.ultraflexgroup.it

Amérique du nord - du sud - centrale:

UFLEX USA

6442 Parkland Drive

Sarasota, FL 34243

Tel: +1.941.351.2628

Email: sales@uflexusa.com

www.uflexusa.com

GARANTIE

La Société **ULTRAFLEX** garantit que ses produits sont fabriqués à règles d'art et qu'ils n'ont aucun défaut de fabrication et de matériels. Cette garantie a une validité de deux années à partir de la date de fabrication des produits à l'exception des cas où ils sont installés et utilisés sur des bateaux de travail ou de commerce, car alors la garantie est limitée à une année de la date de fabrication. Dans le cas où, pendant cette période le produit s'avérerait défectueux à cause des matériaux utilisés ou/et présente des vices de fabrication, le fabricant le remplacera ou le réparera gratuitement. Tout autre dommage direct ou indirect est exclu de la garantie. En particulier la Société constructrice n'est pas responsable et cette garantie ne couvre pas les dommages dérivant d'une installation incorrecte ou d'un emploi inadéquat ou abusif des produits (à l'exception du remplacement ou de la réparation des pièces défectueuses dans les termes et les délais susmentionnés).

Cette garantie ne couvre pas les produits installés sur des bateaux de course ou utilisés pour des compétitions. Les descriptions et les illustrations contenues dans ce manuel sont seulement à titre indicatif. Pour toute information détaillée contacter notre Service d'Assistance.

Les composants des systèmes de conduite **ULTRAFLEX** sont pourvus de la marque **CE** en conformité avec la directive 2013/53/EU. On rappelle que sur les bateaux pourvus de la marque **CE** il est obligatoire d'installer des systèmes de conduite dont les composants sont marqués **CE**.

Nous vous informons que la garantie **ULTRAFLEX** échoit automatiquement au cas où certains composants **ULTRAFLEX** seraient installés dans un système de gouvernement avec des produits de marques différentes.



1 DESCRIPTION DU PRODUIT

1.1 Caractéristiques générales

La barre A95 est fabriquée complètement en acier inoxydable et elle est déjà préassemblée et prête pour être installée. Sa longueur est réglable même après l'avoir installée. Les distances entre-axes varient de 660 mm (26") à 812 mm (32") et de 812 mm (32") à 950 mm (37.5") selon la version (A95-32 et A95-37.5).

NOTE

La distance entre-axes est la distance entre les centres des trous présents sur les bras des moteurs quand ils sont parallèles.

⚠ AVERTISSEMENT

Elle peut être utilisée dans les applications avec moteur hors-bord double et avec vérin double type UC130-SVS (or UC128-OBF et UC128-SVS) pour montage frontal.

⚠ AVERTISSEMENT

Avant de commencer l'installation, vérifier encore la compatibilité de montage de la barre A95 avec votre application.

⚠ AVERTISSEMENT

En général, la barre A95 permet d'incliner les moteurs indépendamment, l'utilisateur doit le contrôler.

⚠ ATTENTION

Dans les applications avec vérin double, il faut commander un vérin standard pourvu de bras de renvoi assemblé dans le tribord et un vérin pourvu de bras de renvoi assemblé dans le bâbord.

⚠ AVERTISSEMENT

Pour permettre la polymérisation correcte des freins filets, attendre 24 heures après l'assemblage de la barre avant l'utilisation.

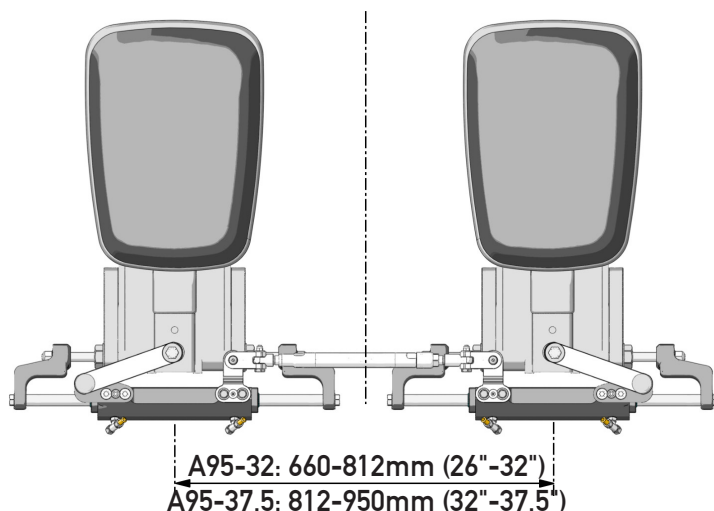

1.2 Contenu emballage

1. Barre préassemblée
2. Sac avec vis

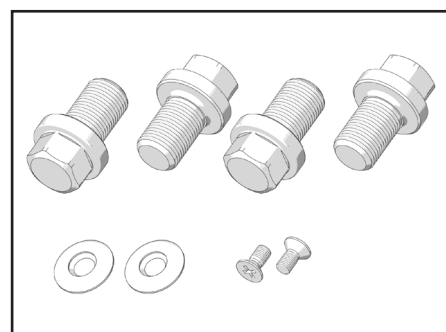
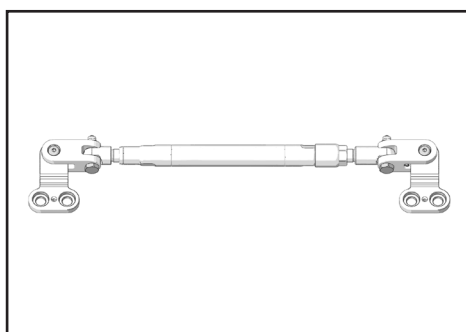

2 INSTALLATION

2.1 Outils nécessaires



Clé hexagonale 14 mm



2x

Clé hexagonale 22 mm



Clé dynamométrique



Tournevis cruciforme



Loctite® 270



Clé mâle six pans de 4mm

2.2 Installation A95

1 Installer les vérins en consultant les instructions fournies à l'intérieur de leur manuel et en positionnant les moteurs comme indiqué dans les figures au point 2.

NOTE

Ne pas assembler les bouchons fournis sur le corps du cylindre (voir figure à côté).
Si les bouchons sont déjà assemblés, il faut les enlever.

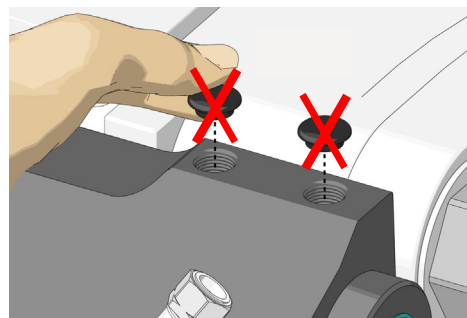

2 Positionner les moteurs au centre de la course comme indiqué dans la figure à côté en respectant la convergence ou la divergence éventuelle recommandée par les fabricants des moteurs (voir figures ci-dessous).

NOTE

Avec la même distance entre-axes des moteurs, la longueur "L" de la barre variera en fonction de l'angle de convergence ou de divergence choisi.

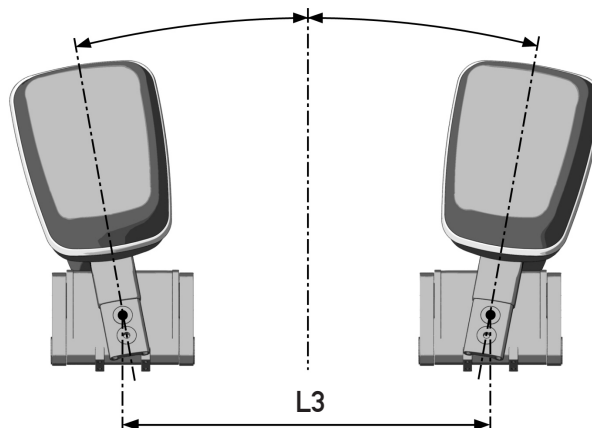
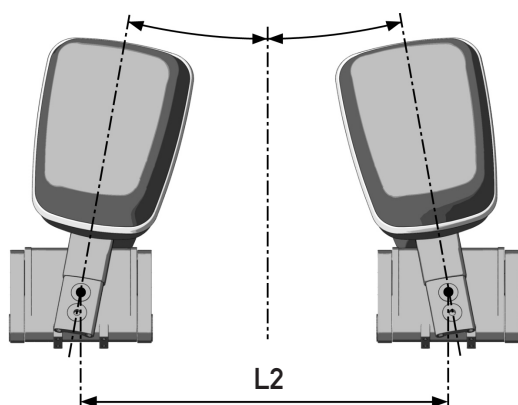
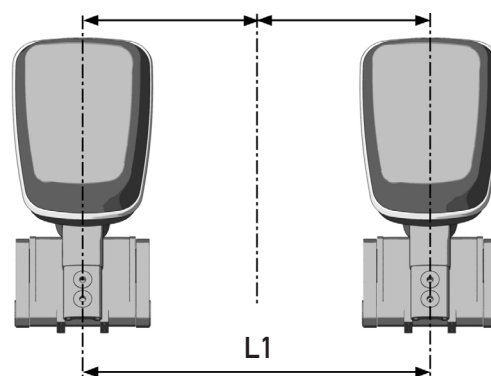

⚠ AVERTISSEMENT

Pour le réglage de l'angle de convergence ou de divergence, suivre tout ce qui est indiqué par le constructeur du moteur, en imposant dans tous les cas et dans n'importe quelle direction un angle total non supérieur à 5° et une différence entre les mesures "A" (mesure de la distance entre-axe des moteurs sur le bateau) et "B" (distance entre les axes des hélices) inférieure à 1" (25.4mm) (voir figure).

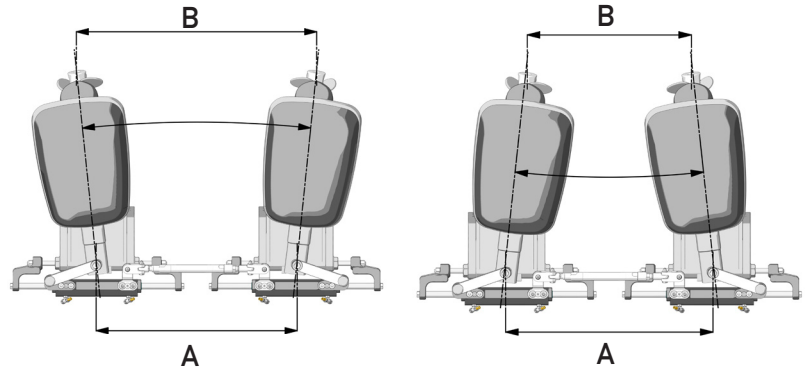

⚠ AVERTISSEMENT

Suivre exactement la procédure de réglage des moteurs.

- 3 Régler la longueur de la barre en vissant et en dévissant les deux articulations à rotule (1) de la même mesure selon la distance entre-axes L1 des moteurs.

DISTANCE ENTRE-AXES MOTEURS	LONGUEUR INDICATIVE DE LA BARRE L
26"	455 mm (18")
27"	480 mm (19")
28"	508 mm (20")
29"	533 mm (21")
30"	559 mm (22")
31"	584 mm (23")
32"	608 mm (24")
34	660 mm (26")
36	711 mm (28")
37.5"	747 mm (29.5")

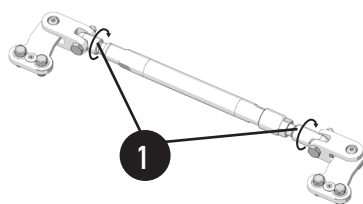

NOTE

Pour chaque partie, on peut obtenir une extension maximale de 76 mm (3") dans la version A95-32 et de 70 mm (2.75") pour la version A95-37.5.

⚠ AVERTISSEMENT

NE PAS FORCER LE DEVISSAGE DES EMBOUTS QUAND ON ATTEINT L'EXTENSION MAXIMALE.

⚠ DANGER

FORCER LE DEVISSAGE DES EMBOUTS PEUT ENDOMMAGER IRRÉMÉDIABLEMENT LA BARRE.

NOTE

Faire attention à ne pas endommager le filetage exposé: des bosselures sur le filetage provoquent du grip-page des parties.

NOTE

La corrélation de la distance entre-axes L2 ou L3 et la longueur de la barre dépend de l'angle de divergence ou de convergence choisi.



4 Assembler l'étrier (2) sur le corps cylindre (3) en utilisant les vis fournies (4). Serrer les vis avec un couple de serrage de 95[Nm] (70 [lb-ft]) à l'aide d'une clé ouverte de 14mm.

⚠ DANGER

Le desserrage des vis provoque une détérioration et une inefficacité conséquente du frein filet pré-appliqué. En cas de desserrage des vis, elles doivent être remplacées.

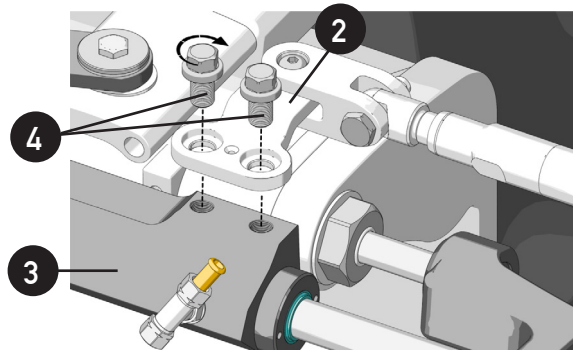

5 Positionner la rondelle de sécurité (5) et la bloquer à l'aide de la vis (6) en appliquant frein de vis comme Loctite® 270 ou équivalent avec un couple de serrage 3[Nm] (2 [lb-ft]).

⚠ DANGER

La non-utilisation de la vis (6) et de la rondelle de sécurité (5) provoque des dommages aux personnes ou aux choses.

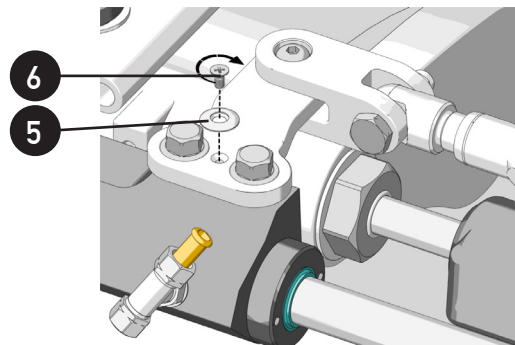

6 A l'aide de la clé mâle six pans (7) serrer les goujons (8) déjà insérés dans l'étrier avec le couple de serrage 24,6 Nm [18,14 lb-ft].

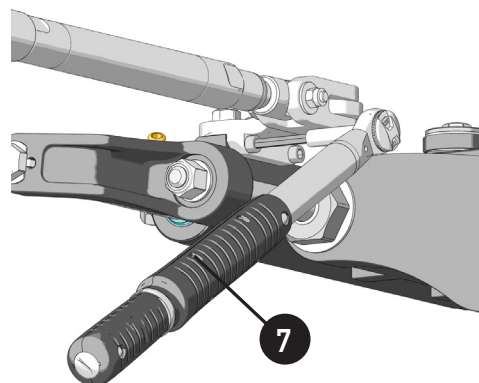
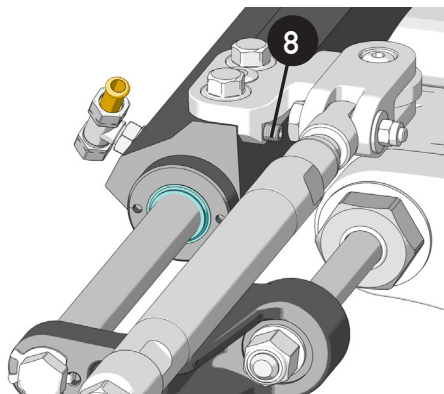

7 Si nécessaire, procéder au réglage fin (paragraphe 2.3) sinon procéder directement au serrage de la bague (point 2, paragraphe 2.3).

⚠ DANGER

Si la bague n'est pas serrée pendant l'emploi de la barre, cela peut causer des dommages aux personnes ou aux choses.



2.3 Réglage fin



Après l'installation et avant d'avoir serré le collier (1), il pourrait être nécessaire de régler finement la longueur de la barre afin d'obtenir l'alignement correct des moteurs.

- 1 A l'aide d'une clé de 22 mm agir sur un des éléments d'extrémité (3) ou (2) et effectuer le réglage fin de la longueur de la barre.

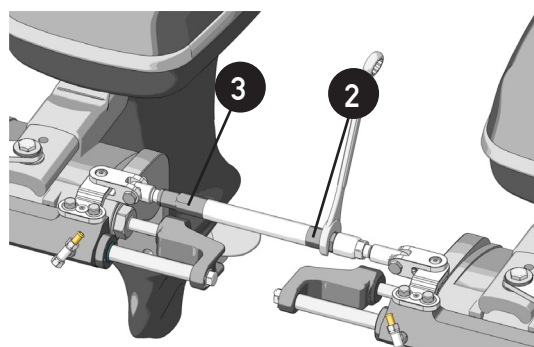

- 2 Une fois le réglage fin effectué, serrer le collier (1) à l'aide d'une clé de 22 mm avec un couple de serrage de 40[Nm] (29,52 [lb·ft]) en utilisant une deuxième clé sur l'élément d'extrémité (2).

⚠ AVERTISSEMENT

Vérifier s'il est possible d'incliner le moteur, de façon indépendante et dans des différentes positions de direction.

⚠ ATTENTION

La barre et/ou les connexions de la barre elle-même ne doivent, en aucun cas, constituer une limitation à la direction permise par le système de gouvernail installé et au relevage des moteurs eux-mêmes.

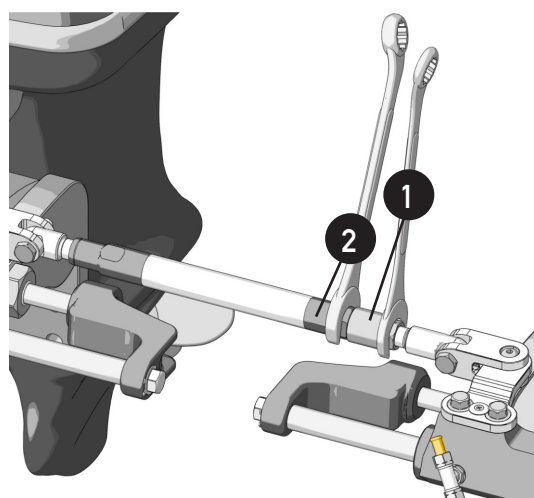

2.4 Réglage de la distance entre-axes avec la barre installée



Si pendant l'emploi du bateau il est nécessaire de varier la distance entre-axes des moteurs (c'est-à-dire l'angle de divergence ou de convergence), suivre la procédure suivante.

⚠ AVERTISSEMENT

Avant d'effectuer les opérations suivantes, il est obligatoire d'éteindre les moteurs et d'opérer dans le respect des conditions de sécurité.

- 1 En utilisant une clé de 22 mm desserrer la bague (1) en la bloquant à l'aide d'une deuxième clé sur l'élément d'extrémité (2).

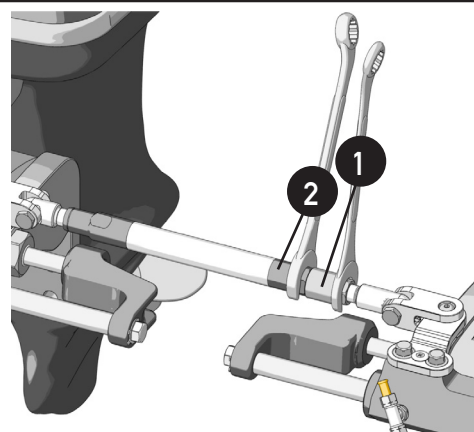

- 2 Suivre comme indiqué dans le paragraphe 2.3.



3 ENTRETIEN

3.1 Entretien ordinaire



⚠ AVERTISSEMENT

La non-observation des contrôles d'entretien peut causer la perte de guidage avec des dommages matériels et/ou des lésions personnelles.

- Après les 10 premières heures d'emploi et ensuite périodiquement vérifier l'intégrité de la barre et le serrage des connexions.

- A: 10 [Nm] (7,38 [lb·ft])
- B: 23 [Nm] (16,96 [lb·ft])
- C: 95 [Nm] (70 [lb·ft])
- D: 3 [Nm] (2 [lb·ft]).
- E: 40 [Nm] (29,52 [lb·ft])
- F: 24,6 [Nm] (18,14 [lb·ft])

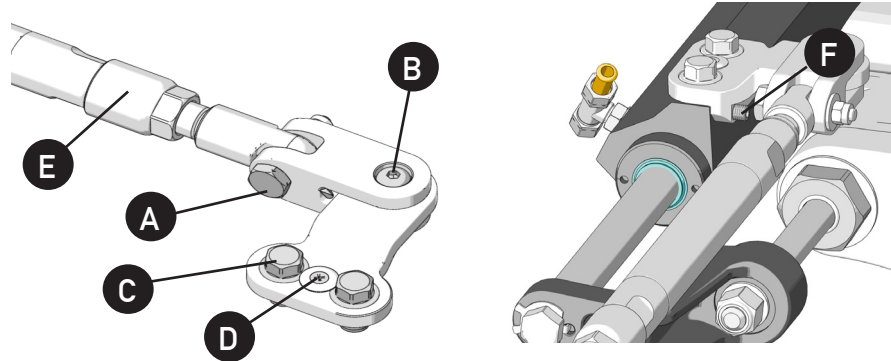

- Laver les composants périodiquement avec de l'eau douce afin d'enlever les dépôts de sel éventuels.

⚠ DANGER

Au cas où les écrous autofreinés et les éléments C et F (voir les figures au-dessus) seraient désassemblés, il faut les remplacer. (Contacter notre service d'assistance).

3.2 Entretien extraordinaire



Assistance technique

Pour n'importe quelle information ou pour assistance relative à des applications particulières, nous vous invitons à contacter notre service d'assistance technique (Voir paragraphe "Lettre d'information").

4 DEMOLITION

4.1 Démolition

Si la barre d'accouplement doit être mise hors service pour quelques raisons que ce soit, les règles fondamentales suivantes doivent être observées pour la protection de l'environnement.

Gaines, conduits flexibles, composants de matériel plastique ou non métalliques, devront être désassemblés et éliminés séparément.

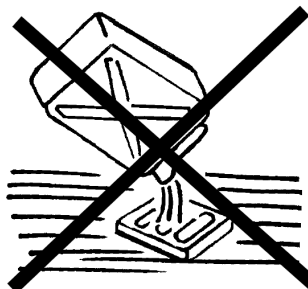

NOTES

NOTES

ULTRAFLEX S.p.A.

16015 Casella (Genova) Italia - Via Crose, 2