



SHURFLO® AQUA KING™ II FRESH WATER PUMPS

PREMIUM 4.0 GPM AND SUPREME 5.0 GPM

MODEL SERIES 4148 & 4158

The NEW SHURFLO AQUA KING™ II delivers smooth and high-powered flow.

SHURFLO's New 4148 and 4158 series fresh water pump design was created with unique over-molded single-piece diaphragm and internal by-pass, assuring long life and top performance in all plumbing systems. Designed as the next legendary pump to exceed the expectations of our customers, the 4148 and 4158 series pumps are constructed for high flow demand, smooth flow and no rapid cycling. Our quality reputation has been built on the reliability and dependability of every pump we build. The 4148 and 4158 series fresh water automatic demand pumps are quiet, thermally protected and can run dry without damage.



FEATURES

- 4 independent chambers
- Co-Molded diaphragm
- Adjustable switch and by-pass
- Self-priming up to 6 feet
- Dry run capability
- Sealed switch
- Sealed motor
- Corrosion resistant electro coated motor
- Thermally protected
- Ignition protected, CE

INSTALLATION TIPS

- Properly sized plumbing
- Mount on a solid surface within 6 feet of tank
- Properly sized wiring
- Use proper fuse size
- Install strainer on pump inlet
- Dry and accessible location
- Minimize plumbing elbows and valves
- Flexible high-pressure hose on inlet and outlet

OPERATION TIPS

- Do not adjust switch or bypass settings without contacting customer service
- Pump is designed for intermittent operation only
- Turn off power to the pump when boat is unattended
- Keep your strainer clean for ultimate pump performance
- Do not use pump for Reverse Osmosis filtration system

APPLICATION

- Marine 12V DC or 24V DC fresh water systems—see pump label for rated voltage
- Multi-Fixture, up to 4 fixtures
- General fresh water transfer
- Pressurized water systems in cabins

INSTALLATION

The goal of installation is to provide a quiet, easy to maintain installation with good flow and low back pressure. This can be accomplished with the following guidelines:

- Mount on a solid surface in an accessible location for strainer cleaning and pump maintenance.
- Use flexible high-pressure hose on the pump inlet and outlet [such as SHURFLO Kit 94-591- 01]. The pump ports and strainer should not be connected to plastic or rigid pipe, or the pump's normal motion will transmit through rigid plumbing causing noise, and possibly loosening or cracking components.
- Pump must use an adequate 50-mesh strainer [such as SHURFLO 255 series strainers].
- Use a minimum of 1/2" [13mm] Inner Diameter plumbing. Smaller ID plumbing will cause cavitation, high back pressure, low flow and noise.
- Pump is designed for intermittent duty only: Do not use these pumps for running a Reverse-Osmosis [RO] Filtration System. High pressure continuous duty usage will shorten the life of the pump and is not covered under warranty.

- Wire Size is 14 GA [2.5mm²] MINIMUM, 12GA [4mm²] is recommended— See Wire Chart in Electrical Section for minimum sizing.
- Minimum power requirement is a 15 Amp circuit.
- Reduce restrictions on inlet and outlet. This includes small inner diameter shut-off valves, winterizing valves and elbows.

INSTALLATION GUIDELINES

- Solid surface within 6 feet of tank
- Accessible location
- Minimize flow restrictions in the system
- Strainer on pump inlet
- Properly sized wiring
- Flexible hose on inlet and outlet - Proper electrical protection
- Minimize plumbing elbows and valves
- Properly sized plumbing

MOUNTING

- Mount the pump within 6 feet (Max) of the tank for best performance and pump life. The pump will pull farther, but the farther it pulls the more work it does, increasing vibration and noise, and reducing the output and pump life.
- Mount pump in a space of at least 1 cubic foot for adequate ventilation to prevent overheating.
- Pump may be mounted in any position.
- Mount pump for easy access for cleaning strainer, maintenance and service.
- Mount pump on a solid surface to prevent vibration and noise.

ELECTRICAL

- The pump should be on a dedicated (individual) circuit protected by the specified fuse on the motor label.
- A UL marine duty switch (ignition protected) rated for 15 amps or higher is recommended, and must interrupt current flow on the positive (+ red) lead.

SHUT OFF POWER TO THE PUMP WHEN LEAVING THE BOAT UNATTENDED.

Ft. [m]		AWG [mm ²]	
0-20	[0-6]	14	[2.5]
20-50	[6-15]	12	4]
50-70	[15-21]	10	[6]
70-100	[21-30]	8	[8]

Minimum Wire Size for a 10% voltage drop on a 12VDC, 15 Amp Circuit. Length is the distance from the power source to pump and back to ground.

PLUMBING

Installation of a strainer is required to prevent debris from entering the pump. For noise and vibration reduction we recommend at least 18 in. [.5 M] of 1/2" [13mm] I.D. flexible high-pressure hose to both ports. The pump ports and strainer **should not** be connected to plastic or rigid pipe. This hose should be anchored where it meets the hard plumbing to reduce plumbing vibration.

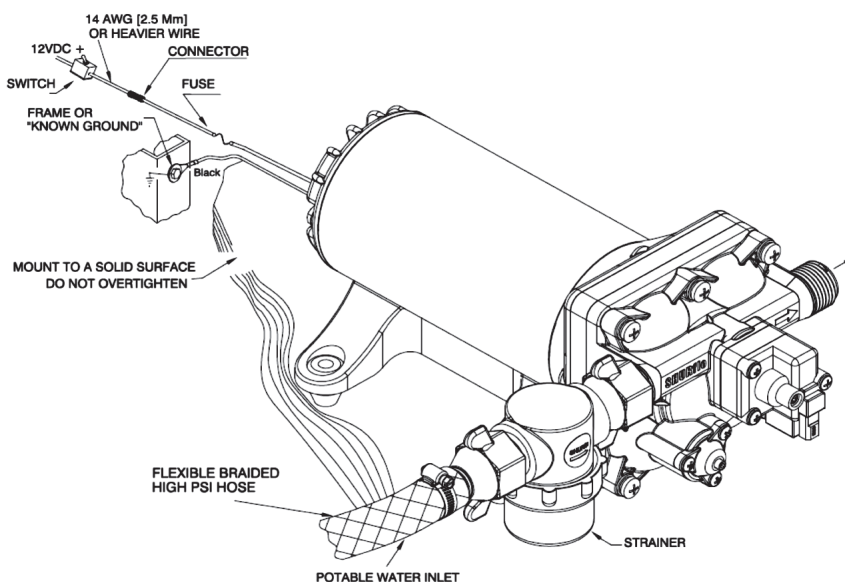

Typical Pump Installation

ABOUT THE BY-PASS

NOTE: By-pass adjustment should only be performed by a qualify technician with proper gauges and equipment.

The bypass is a spring loaded diaphragm that opens up allowing water from the discharge side back to the inlet side. The by-pass is set to begin opening at about 30 psi [2.06 Bar] and creating full by-pass at about 65 psi [4.48 Bar]. The pressure switch on the pump is set to shut off at 55 psi. If the switch or by-pass are adjusted too much, the by-pass and switch shut-off can overlap and **THE PUMP WILL NOT SHUT OFF**. Screwing the switch screw in clockwise will raise the shut-off pressure. Unscrewing the switch screw counterclockwise will lower the pump shut-off pressure. Screwing the by-pass screw in will raise the pressure at which the by-pass starts and raise the maximum by-pass pressure. Unscrewing the by-pass screw counterclockwise will lower the pressure at which by-pass starts and lower the by-pass pressure. **WARNING:** If full by-pass is reached before the shut-off setting, the pump will not shut off. Maximum by-pass pressure setting should be at least 10 psi [0.68 Bar] higher than pump shut off pressure.

OPERATION

This pump is designed for intermittent duty only. The pump operates normally up to about 30 PSI [2.06 Bar], where a spring-loaded by-pass valve opens, allowing flow back from the output side to the input side, providing smooth, steady flow with minimal cycling. As a faucet is opened back up, the pressure will drop, the by-pass will close and full flow is again obtained. This allows good flow, even with today's restrictive showers and pullout sprayer faucets. Performance will vary, of course, depending on the voltage to the pump; lower voltage = lower flow, higher voltage = higher flow. Remember your electrical safety: It is always best to shut power to the pump "OFF" when leaving the Boat unattended.

SANITIZING

Potable water systems require periodic maintenance to keep components working properly and deliver a consistent flow of freshwater. Sanitizing is recommended: prior to storing, after a period of storage, or any time the system is opened or contaminated, as follows:

NOTE: Check your Boat Owner's Manual for specific instructions. By-pass any filters or remove filter cartridges.

1. Determine the amount of common household bleach needed to sanitize the tank.
 - A) 2 ounces of bleach per 15 gallons tank size: 60 gallon tank [15 x 4] = 4 x 2 ounces = 8 ounces of bleach.
 - B) 1 ml bleach per 1 liter tank size: 300 liter tank = 300 milliliters of bleach.
2. Mix the bleach with water in a container such as a gallon jug. If tank is filled through a pressurized fitting, pour the bleach into the hose before attaching the hose to the city water entry.
3. Pour the bleach solution into the tank and fill the tank with potable water. Rock the boat back and forth to coat top and sides of potable water tank.

WINTERIZING

Refer to the boat owner's manual for specific winterizing instructions. If water is allowed to freeze in the system, serious damage to the plumbing and pump may occur. Failures of this type will void the warranty. The best guarantee against damage is to completely drain the pump and perform the following:

1. Drain the water tank. If the tank doesn't have a drain valve, open all faucets allowing the pump to operate until the tank is empty.
2. Open all the faucets (including the lowest valve or drain in the plumbing), allow the pump to purge the water from the plumbing, and then turn the pump "OFF".

4. Open all faucets (Hot & Cold) allowing the water to run until the odor of chlorine is detected. Allow four (4) hours of contact time to disinfect completely. Doubling the solution concentration allows for a contact time of one (1) hour.

5. Drain the tank. Refill the tank and flush the system once or twice until the odor has decreased. The residual chlorine odor and taste is not harmful.

MAINTENANCE

Normal pump maintenance is all that is needed: Checking and cleaning of the strainer, normal sanitizing and winterizing and occasionally checking all plumbing hardware and fittings for tightness. Lack of sanitizing is the number one reason for premature pump failure and poor performance over time. Lack of sanitizing will cause scale build-up on the diaphragm and valves, causing low flow and leak back [occasional pump cycling with no faucets open or tank filling up when hooked up to city water].

3. Using a pan to catch the remaining water, remove the plumbing at the pump's inlet/outlet ports. Turn the pump "ON", allowing it to operate until the water is expelled. Turn "OFF" power to the pump once the plumbing is emptied. Do not reconnect the pump plumbing. Make a note at tank filler as a reminder: "Plumbing is disconnected".

4. All faucets must be left open to guard against any damage.

5. Potable anti-freeze may be poured down drains and toilets to protect p-traps and toilet seals. Sanitize the plumbing system before putting the plumbing system back in service.

TROUBLESHOOTING

Vibration induced by driving can loosen plumbing, strainers and pump hardware. Check for system components that are loose. Also, refer to the chart below for trouble-shooting tips.

PUMP WILL NOT START/ BLOWS CIRCUIT

- ✓ Electrical connections, fuse or breaker, main switch, and ground connection.
- ✓ Is the motor hot? Thermal breaker may have triggered; it will reset when cool.
- ✓ Is voltage present at the switch? Bypass pressure sw. Does the pump operate?
- ✓ Charging System for correct voltage ($\pm 10\%$) and good ground.
- ✓ For an open or grounded circuit, or motor; or improperly sized wire.
- ✓ For seized or locked diaphragm assembly (water frozen?).

WILL NOT PRIME/SPUTTERS (No discharge/Motor runs)

- ✓ Is the strainer clogged with debris?
- ✓ Is there water in the tank, or has air collected in the hot water heater?
- ✓ Is the inlet tubing/plumbing sucking in air at plumbing connections (vacuum leak)?
- ✓ Is inlet/outlet plumbing severely restricted or kinked? Restrictive valves?
- ✓ Proper voltage with the pump operating ($\pm 10\%$).
- ✓ For debris in pump inlet/outlet valves or swollen/dry valves.
- ✓ Pump housing for cracks or loose drive assembly screws.

RAPID CYCLING

- ✓ For restrictive plumbing and flow restrictions in faucets/shower heads.
- ✓ Water filter/purifier should be on separate feed line.
- ✓ Shut-off pressure set too low.

PUMP WILL NOT SHUT-OFF / RUNS WHEN NOZZLE IS CLOSED

- ✓ Output side (pressure) plumbing for leaks, and inspect for leaky valves or toilet.
- ✓ For air trapped in outlet side (water heater) or pump head.
- ✓ For correct voltage to pump ($\pm 10\%$).
- ✓ For loose drive assembly or pump head screws.
- ✓ Are the valves held open by debris or is the rubber swollen?
- ✓ Pressure switch operation. By-pass set higher than shut-off.

NOISY OR ROUGH OPERATION

- ✓ For plumbing which may have vibrated loose.
- ✓ For a restricted inlet (clogged strainer, kinked hose, restrictive valves).

- ✓ Is the pump plumbed with rigid pipe causing noise to transmit?
- ✓ Does the mounting surface amplify noise (flexible)? Does it bang like a drum?
- ✓ For mounting feet that are loose or are compressed too tight.
- ✓ For air in the system. Check all fixtures for air and bleed system.
- ✓ The motor with pump head removed. Is noise from motor or pump head?

LEAKS FROM PUMP HEAD OR SWITCH

- ✓ For loose screws at switch or pump head.
- ✓ Switch diaphragm ruptured or pinched.
- ✓ For punctured diaphragm if water is present in drive assembly.

SERVICE KITS

ITEM	4148-153-X75 PART #	4148-163-X75 PART #	4158-153-X75 PART #	4158-163-X75 PART #
1	94-801-10*	94-801-10*	94-801-10*	94-801-10*
2	94-800-01	94-800-01	94-800-01	94-800-01
3	94-801-02	94-801-02	94-801-12	94-801-12
4	94-71-001-07	94-71-001-03	94-71-000-17	94-71-001-04
1, 2, 3	94-801-11*	94-801-11*	94-801-13*	94-801-13*
Check Valve (not shown)	94-800-03	94-800-03	94-800-03	94-800-03

*With preset switch and by-pass adjustment

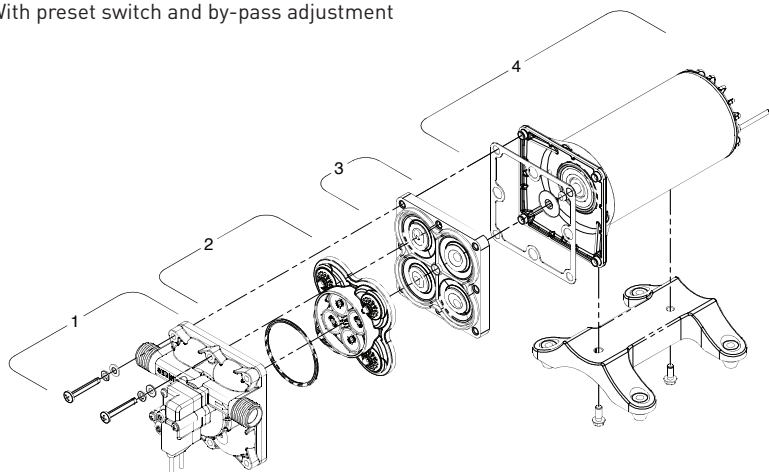

3545 HARBOR GATEWAY SOUTH, SUITE 103, COSTA MESA, CA 92626, (800) 854-3218 WWW.SHURFLO.COM

All Pentair trademarks and logos are owned by Pentair, Inc. All other brand or product names are trademarks or registered marks of their respective owners. Because we are continuously improving our products and services, Pentair reserves the right to change specifications without prior notice. Pentair is an equal opportunity employer.

911-1026 Rev. F 07/15 ©Pentair, Inc. All Rights Reserved.